

<b>DE</b>	Gebrauchsanleitung / Montageanleitung	<b>2</b>
<b>FR</b>	Mode d'emploi / Instructions de montage	<b>3</b>
<b>EN</b>	Instructions for use / assembly instructions	<b>4</b>
<b>IT</b>	Istruzioni per l'uso / Istruzioni per Installazione	<b>5</b>
<b>ES</b>	Modo de empleo / Instrucciones de montaje	<b>6</b>
<b>NL</b>	Gebruiksaanwijzing / Handleiding	<b>7</b>
<b>DK</b>	Brugsanvisning / Monteringsvejledning	<b>8</b>
<b>PT</b>	Instruções para uso / Manual de Instalação	<b>9</b>
<b>PL</b>	Instrukcja obsługi / Instrukcja montażu	<b>10</b>
<b>CS</b>	Návod k použití / Montážní návod	<b>11</b>
<b>SK</b>	Návod na použitie / Montážny návod	<b>12</b>
<b>ZH</b>	用户手册 / 组装说明	<b>13</b>
<b>RU</b>	Руководство пользователя / Инструкция по монтажу	<b>14</b>
<b>HU</b>	Használati útmutató / Szerelési útmutató	<b>15</b>
<b>FI</b>	Käyttöohje / Asennusohje	<b>16</b>
<b>SV</b>	Bruksanvisning / Monteringsanvisning	<b>17</b>
<b>LT</b>	Vartotojo instrukcija / Montavimo instrukcijos	<b>18</b>
<b>HR</b>	Upute za uporabu / Uputstva za instalaciju	<b>19</b>
<b>TR</b>	Kullanım kılavuzu / Montaj kılavuzu	<b>20</b>
<b>RO</b>	Manual de utilizare / Instrucțiuni de montare	<b>21</b>
<b>EL</b>	Οδηγίες χρήσης / Οδηγία συναρμολόγησης	<b>22</b>
<b>SL</b>	Navodilo za uporabo / Navodila za montažo	<b>23</b>
<b>ET</b>	Kasutusjuhend / Paigaldusjuhend	<b>24</b>
<b>LV</b>	Lietošanas pamācība / Montāžas instrukcija	<b>25</b>
<b>SR</b>	Uputstvo za upotrebu / Uputstvo za montažu	<b>26</b>
<b>NO</b>	Bruksanvisning / Montasjeveiledning	<b>27</b>
<b>BG</b>	Инструкция за употреба / Инструкция за употреба	<b>28</b>
<b>SQ</b>	Udhëzuesi i përdorimit / Udhëzime rreth montimit	<b>29</b>
<b>AR</b>	دليل الاستخدام / تعليمات التجميع	<b>30</b>

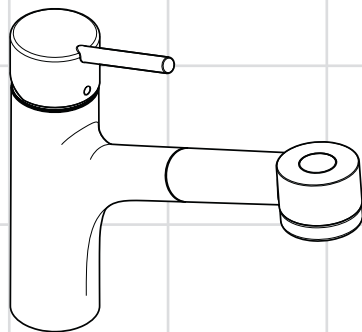

**Talis S**  
32841XXX



## **Sicherheitshinweise**

- ⚠ Bei der Montage müssen zur Vermeidung von Quetsch- und Schnittverletzungen Handschuhe getragen werden.
- ⚠ Große Druckunterschiede zwischen den Kalt- und Warmwasseranschlüssen müssen ausgeglichen werden.

## **Montagehinweise**

- Die Armatur muss nach den gültigen Normen montiert, gespült und geprüft werden!

## **Technische Daten**

Betriebsdruck:	max. 1 MPa
Empfohlener Betriebsdruck:	0,1 - 0,5 MPa
Prüfdruck:	1,6 MPa
(1 MPa = 10 bar = 147 PSI)	
Heißwassertemperatur:	max. 80 °C
Empfohlene Heißwassertemperatur:	65 °C
Durchflussleistung bei 0,3 MPa:	
Durchflussleistung Brausestrahl:	8 l/min
Durchflussleistung Luftsprudler:	10 l/min
Eigensicher gegen Rückfließen	

Hansgrohe Armaturen können in Verbindung mit hydraulisch und thermisch gesteuerten Durchlauferhitzern eingesetzt werden, wenn der Fließdruck mindestens 0,15 MPa beträgt.



## **Wartung** (siehe Seite 31)

Rückflussverhinderer müssen gemäß DIN EN 1717 regelmäßig in Übereinstimmung mit nationalen oder regionalen Bestimmungen (DIN 1988 einmal jährlich) auf ihre Funktion geprüft werden.



Einhandmischer mit Warmwasserbegrenzung, Justierung siehe Seite 34. In Verbindung mit Durchlauferhitzern ist eine Warmwassersperre nicht notwendig.



Kein essigsäurehaltiges Silikon verwenden!



## **Maße** (siehe Seite 31)



## **Serviceteile** (siehe Seite 35)



## **Bedienung** (siehe Seite 36)



## **Reinigung** (siehe Seite 31) und beiliegende Broschüre

Bei vermindertem Wasserdurchsatz Schmutzfangsieb zwischen Faustbrause und Schlauch reinigen.



## **Prüfzeichen** (siehe Seite 36)





## Consignes de sécurité

- ⚠ Lors du montage, porter des gants de protection pour éviter toute blessure par écrasement ou coupure.
- ⚠ Il est conseillé d'équilibrer les pressions de l'eau chaude et froide.

## Instructions pour le montage

- La robinetterie doit être installée, rincée et contrôlée conformément aux normes valables!

## Informations techniques

Pression de service autorisée:	max. 1 MPa
Pression de service conseillée:	0,1 - 0,5 MPa
Pression maximum de contrôle: (1 MPa = 10 bar = 147 PSI)	1,6 MPa
Température d'eau chaude:	max. 80 °C
Température recommandée:	65 °C
Débit à 0,3 MPa:	
Débit du jet d'eau:	8 l/min
Débit du tourbillon d'air:	10 l/min
Avec dispositif anti-retour	

Les mitigeurs Hansgrohe fonctionnent également en association à des chauffe-eau à commande hydraulique ou thermique à condition que la pression soit au minimum de 0,15 MPa.



## Entretien (voir page 31)

Les clapets anti-retour doivent être examinés régulièrement conformément à la norme EN 1717 ou conformément aux dispositions nationales ou régionales quant à leur fonction (au moins une fois par an).



Mitigeur avec limitation de la température: consulter la page 34 pour le réglage. Une limitation de la température n'est pas nécessaire quand le mitigeur est alimenté par un chauffe-eau instantané.



Ne pas utiliser de silicone contenant de l'acide acétique!



## Dimensions (voir page 31)



## Pièces détachées (voir pages 35)



## Instructions de service (voir page 36)



## Nettoyage (voir page 31) et brochure ci-jointe

En cas de baisse du débit dévisser la douche poing et nettoyer le filtre.





## Classification acoustique et débit (voir page 36)





## Safety Notes

-  Gloves should be worn during installation to prevent crushing and cutting injuries.
-  The hot and cold supplies must be of equal pressures.

## Installation Instructions

- The fitting must be installed, flushed and tested after the valid norms!

## Technical Data

Operating pressure:	max. 1 MPa
Recommended operating pressure:	0,1 - 0,5 MPa
Test pressure:	1,6 MPa
(1 MPa = 10 bar = 147 PSI)	
Hot water temperature:	max. 80 °C
Recommended hot water temp.:	65 °C
Rate of flow by 0,3 MPa:	
Handspray flow rate:	8 l/min
Aerator flow rate:	10 l/min
anti-pollution function	

Hansgrohe mixers can be used together with hydraulically and thermally controlled continuous flow heaters if the flow pressure is at least 0,15 MPa.



## Maintenance (see page 31)

The non return valves must be checked regularly according to DIN EN 1717 in accordance with national or regional regulations (at least once a year).



To adjust the hot water limiter on single lever mixers, please see page 34. No adjustment is necessary when using a continuous flow water heater.



Do not use silicone containing acetic acid!



## Dimensions (see page 31)



## Spare parts (see page 35)



## Operation (see page 36)



## Cleaning (see page 31) and enclosed brochure

If the waterflow drops, clean the filter located between hose and handspray.





## Test certificate (see page 36)





## **Indicazioni sulla sicurezza**

-  Durante il montaggio, per evitare ferite da schiacciamento e da taglio bisogna indossare guanti protettivi.
-  Attenzione! Compensare le differenze di pressione tra i collegamenti dell'acqua fredda e dell'acqua calda.

## **Istruzioni per il montaggio**

- La rubinetteria deve essere installata, pulita e testata secondo le istruzioni riportate!

## **Dati tecnici**

Pressione d'uso:	max. 1 MPa
Pressione d'uso consigliata:	0,1 - 0,5 MPa
Pressione di prova:	1,6 MPa
(1 MPa = 10 bar = 147 PSI)	
Temperatura dell'acqua calda:	max. 80 °C
Temp. dell'acqua calda consigliata:	65 °C
Potenza di erogazione a 0,3 MPa:	
Potenza di erogazione del getto:	8 l/min
Potenza di erogazione del rompigetto:	10 l/min
Sicurezza antiriflusso	

I miscelatori Hansgrohe possono venire usati con caldaie a „bassa pressione“ se la pressione di flusso è almeno di 0,15 MPa.



## **Manutenzione** (vedi pagg. 31)

La valvola di non ritorno deve essere controllata regolarmente come da DIN EN 1717, secondo le normative nazionali e regionali (almeno una volta all'anno).



Regolazione del limitatore di erogazione di acqua calda dei miscelatori monocomando, vedere pagina 34. In combinazione con le caldaie istantanee, il limitatore di erogazione di acqua calda non è necessario.



Non utilizzare silicone contenente acido acetico!



## **Ingombri** (vedi pagg. 31)



## **Parti di ricambio** (vedi pagg. 35)



## **Procedura** (vedi pagg. 36)



## **Pulitura** (vedi pagg. 31) e brochure allegata

In caso di diminuzione dell'erogazione pulire il filtro situato tra la doccetta ed il flessibile.





## **Segno di verifica** (vedi pagg. 36)





## **Indicaciones de seguridad**

-  Durante el montaje deben utilizarse guantes para evitar heridas por aplastamiento o corte.
-  Grandes diferencias de presión en servicio entre agua fría y agua caliente deben equilibrarse.

## **Indicaciones para el montaje**

- El grifo tiene que ser instalado, probado y testado, según las normas en vigor.

## **Datos técnicos**

Presión en servicio:	max. 1 MPa
Presión recomendada en servicio:	0,1 - 0,5 MPa
Presión de prueba:	1,6 MPa
(1 MPa = 10 bar = 147 PSI)	
Temperatura del agua caliente:	max. 80 °C
Temp. recomendada del agua caliente:	65 °C
Caudal a 0,3 MPa:	
Caudal chorro de ducha:	8 l/min
Caudal aireador:	10 l/min
Seguro contra el retorno	

Los mezcladores Hansgrohe pueden ser utilizados junto con calentadores continuos de agua que sean manejados de manera hidráulica o térmica, siempre que la presión en servicio ascienda a un mínimo de 0,15 MPa.



## **Mantenimiento** (ver página 31)

Las válvulas anti-retorno tienen que ser controladas regularmente según la norma DIN EN 1717, en acuerdo con las regulaciones nacionales o regionales (una vez al año, por lo menos).



Uso como mezclador monomando con limitación del caudal de agua caliente: ver ajuste en pagina 34. En combinación con calentadores instantáneos no es necesario limitar el caudal de agua caliente.



No utilizar silicona que contiene ácido acético!



## **Dimensiones** (ver página 31)



## **Repuestos** (ver página 35)



## **Manejo** (ver página 36)



## **Limpiar** (ver página 31) y folleto anexo

En el caso que se redujera el caudal deberá limpiarse el filtro situado entre la ducha de mano y el tubo.





## **Marca de verificación** (ver página 36)





## Veiligheidsinstructies

-  Bij de montage moeten ter voorkoming van kniel- en snijwonden handschoenen worden gedragen.
-  Grote drukverschillen tussen de kouden warm wateraansluitingen dienen vermeden te worden.

## Montage-instructies

- Leidingen doorspoelen volgens Norm. De mengkraan vervolgens monteren en controleren!

## Technische gegevens

Werkdruk: max.	max. 1 MPa
Aanbevolen werkdruk:	0,1 - 0,5 MPa
Getest bij:	1,6 MPa
(1 MPa = 10 bar = 147 PSI)	
Temperatuur warm water:	max. 80 °C
Aanbevolen warm water temp.:	65 °C
Doorvoercapaciteit bij 0,3 MPa:	
Doorstroomcapaciteit douchestraal:	8 l/min
Doorstroomcapaciteit perlator:	10 l/min
Beveiligd tegen terugstromen	

Hansgrohe kranen kunnen samen met hydraulisch en thermisch gestuurde geisers gebruikt worden indien de uitstroomdruk min. 0,15 MPa bedraagt.



## Onderhoud (zie blz. 31)

Keerkleppen moeten volgens DIN EN 1717 regelmatig en volgens plaatselijk geldende eisen op het functioneren gecontroleerd worden. (Tenminste een keer per jaar).



Eéngreepsmengkranen met warmwaterbegrenzing, instelling zie blz. 34. In combinatie met geisers is een warmwaterbegrenzing niet noodzakelijk.



Gebruik geen zuurhoudende silicone!



## Maten (zie blz. 31)



## Service onderdelen (zie blz. 35)



## Bediening (zie blz. 36)



## Reinigen (zie blz. 31) en bijgevoegde brochure

Bij verminderde waterdoorvoer zeefje tussen vuistdouche en slang schoonmaken.



## Keurmerk (zie blz. 36)



**Montage zie blz. 32**



## Sikkerhedsanvisninger

- ⚠ Ved monteringen skal der bruges handsker for at undgå kvæstelser og snitsår.
- ⚠ Større trykforskelle mellem koldt og varmt vand bør udjævnes.

## Monteringsanvisninger

- Ifølge gældende regler, skal armaturet monteres, skylles igennem og afprøves.

## Tekniske data

Driftstryk:	max. 1 MPa
Anbefalet driftstryk:	0,1 - 0,5 MPa
Prøvetryk:	1,6 MPa
(1 MPa = 10 bar = 147 PSI)	
Varmvandstemperatur:	max. 80 °C
Anbefalet varmtvandstemperatur:	65 °C
Gennemstrømningsydelse ved 0,3 MPa:	
Cirkulationsmængde brusestråle:	8 l/min
Cirkulationsmængde luftdyse:	10 l/min
Med indbygget kontraventil	

Hansgrohe armaturer kan anvendes i forbindelse med hydraulisk- og termiskstyrede gennemstrømningsvandvarmere ved et vandtryk på 0,15 MPa.



## Service (se s. 31)

Ifølge DIN EN 1717 skal gennemstrømningsbegrænsere i overensstemmelse med nationale regler afprøves regelmæssigt (mindst en gang om året).



Etgrebsarmaturer med varmtvandsbegrænsning, justering se side 34. I forbindelse med gennemstrømningsvandvarmer er en varmtvandsbegrænsning ikke nødvendig.



Der må ikke benyttes eddikesyreholdig silikone!



## Målene (se s. 31)



## Reservedele (se s. 35)



## Brugsanvisning (se s. 36)



## Rengøring (se s. 31) og vedlagt brochure

Bij verminderde waterdoorvoer zeefje tussen vuistdouche en slang schoonmaken.



## Godkendelse (se s. 36)







## Avisos de segurança

- ⚠ Durante a montagem devem ser utilizadas luvas de protecção, de modo a evitar ferimentos resultantes de entalamentos e de cortes.
- ⚠ Grandes diferenças entre as pressões das águas quente e fria devem ser compensadas.

## Avisos de montagem

- A misturadora deve ser instalada, purgada e testada de acordo com as normas em vigor!

## Dados Técnicos

Pressão de funcionamento:	max. 1 MPa
Pressão de func. recomendada:	0,1 - 0,5 MPa
Pressão testada:	1,6 MPa
(1 MPa = 10 bar = 147 PSI)	
Temperatura da água quente:	max. 80 °C
Temp. água quente recomendada:	65 °C
Caudal a 0,3 MPa:	
Caudal do chuveiro:	8 l/min
Caudal do emulsor:	10 l/min
Função anti-retorno e anti-vácuo	

As misturadoras Hansgrohe podem ser utilizadas com esquentadores (de controlo térmico ou hidráulico) desde que a pressão de utilização seja, no mínimo, de 0,15 MPa.



## Manutenção (ver página 31)

As válvulas anti-retorno devem ser verificadas regularmente de acordo com a DIN EN 1717 segundo os regulamentos nacionais ou regionais (pelo menos uma vez por ano).



Misturadora monocomando equipada com limitador de temperatura (vide pàg. 34). Em combinação com caldeira ou esquentador instantâneo o limitador de água quente não se aplica.



Não utilizar silicone que contenha ácido acético!



## Medidas (ver página 31)



## Peças de substituição (ver página 35)



## Funcionamento (ver página 36)



## Limpeza (ver página 31) e brochura em anexo

Se notar uma diminuição acentuada do caudal, convém limpar o filtro que está entre o flexível e a cabeça do chuveiro.



## Marca de controlo (ver página 36)





## Wskazówki bezpieczeństwa

- ⚠ Aby uniknąć zranień, takich jak zgniecenia czy przecięcia, podczas montażu należy nosić rękawice.
- ⚠ Znaczne różnice ciśnień na dopływach ciepłej i zimnej wody muszą zostać wyrównane.

## Wskazówki montażowe

- Armatura musi być zamontowana, przepłukana i wypróbowana według obowiązujących norm!

## Dane techniczne

Ciśnienie robocze:	maks. 1 MPa
Zalecane ciśnienie robocze:	0,1 - 0,5 MPa
Ciśnienie próbne: (1 MPa = 10 bary = 147 PSI)	1,6 MPa
Temperatura wody gorącej:	maks. 80 °C
Zalecana temperatura wody gorącej:	65 °C
Wydajność przepływu przy 0,3 MPa:	
Wydajność przepływu strumienia prysznica:	8 l/min
Wydajność przepływu przez napowietrzacz:	10 l/min
Samoistnie zabezpieczony przed przepływem zwrotnym	

Armatura Hansgrohe może być stosowana z przepływowymi podgrzewaczami wody sterowanymi hydraulicznie i termicznie w przypadku, gdy ciśnienie przepływu wynosi co najmniej 0,15 MPa.



## Konserwacja (patrz strona 31)

Działanie zabezpieczeń przed przepływem zwrotnym, zgodnie z normą DIN EN 1717 i miejscowymi przepisami, musi być kontrolowane (DIN 1988, raz w roku).



Mieszacz jednoręczny z ogranicznikiem temperatury wody, ustawianie, patrz str. 34. W połączeniu z przepływowym podgrzewaczem wody ogranicznik temperatury wody nie jest konieczny.



Nie stosować silikonów zawierających kwas octowy!



## Wymiary (patrz strona 31)



## Części serwisowe (patrz strona 35)



## Obsługa (patrz strona 36)



## Czyszczenie (patrz strona 31) i dołączona broszura

Przy niskim ciśnieniu wody, wyczyścić sitko pomiędzy prysznicem ręcznym a wężem.





## Znak jakości (patrz strona 36)





## **Bezpečnostní pokyny**

-  Pro zabránění řezným zraněním a pohmožděním je nutné při montáži nosit rukavice.
-  Je nutné vyrovnat velké rozdíly tlaku mezi přípoji studené a teplé vody.

## **Pokyny k montáži**

- Armatura se musí montovat, proplachovat a testovat podle platných norem!

## **Technické údaje**

Provozní tlak:	max. 1 MPa
Doporučený provozní tlak:	0,1 - 0,5 MPa
Zkušební tlak:	1,6 MPa
(1 MPa = 10 bar = 147 PSI)	
Teplota horké vody:	max. 80 °C
Doporučená teplota horké vody:	65 °C
Průtokové množství při 0,3 MPa:	
Průtokové množství sprchy:	8 l/min
Průtokové množství perlátoru:	10 l/min
Vlastní jističení proti zpětnému nasátí.	

Armatury Hansgrohe je možno používat v kombinaci s hydraulicky a tepelně řízenými průtokovými ohřivači v případě, že tlak činí minimálně 0,15 MPa.



## **Údržba** (viz strana 31)

U zpětných ventilů se musí podle DIN EN 1717 v souladu s národními nebo regionálními předpisy testovat jejich funkčnost (alespoň jednou ročně).



Páková baterie s omezením horké vody, seřízení viz. str. 34. Ve spojení s průtokovými ohřivači není uzávěr teplé vody nutný.



Nepoužívat silikon s obsahem kyseliny octové!



## **Rozměry** (viz strana 31)



## **Servisní díly** (viz strana 35)



## **Ovládání** (viz strana 36)



## **Čištění** (viz strana 31) a přiložená brožura

Při sníženém průtoku vyčistit sítko zachycující nečistoty mezi sprchou a hadicí.



## **Zkušební značka** (viz strana 36)





## **Bezpečnostné pokyny**

- ⚠ Pri montáži musíte nosiť rukavice, aby ste predišli pomliaždeninám a rezným poraneniam.
- ⚠ Veľké rozdiely v tlaku medzi prípojkami studenej a teplej vody musia byť vyrovnané.

## **Pokyny pre montáž**

- Batéria sa musí montovať, preplachovať a testovať podľa platných noriem!

## **Technické údaje**

Prevádzkový tlak:	max. 1 MPa
Doporučený prevádzkový tlak:	0,1 - 0,5 MPa
Skúšobný tlak:	1,6 MPa
(1 MPa = 10 bar = 147 PSI)	
Teplota teplej vody:	max. 80 °C
Doporučená teplota teplej vody:	65 °C
Prietokové množstvo pri 0,3 MPa:	
Prietokové množstvo prúdu vody v sprche:	8 l/min
Prietokové množstvo perlátora sprchy:	10 l/min
Vlastná poistka proti spätnému nasatiu.	

Batérie Hansgrohe môžete používať v spojení s hydraulickými a tepelne ovládanými prietokovými ohrievačmi, ak je tlak minimálne 0,15 MPa.



## **Údržba** (viď strana 31)

Pri spätných ventiloch sa musí podľa DIN EN 1717 v súlade s národnými alebo regionálnymi predpismi testovať ich funkčnosť (aspoň raz ročne).



Páková batéria s obmedzením teplej vody, nastavenie viď.str. 34. V spojení s prietokovými ohrievačmi nie je uzáver teplej vody nutný.



Nepoužívať silikón s obsahom kyseliny octovej!



## **Rozmery** (viď strana 31)



## **Servisné diely** (viď strana 35)



## **Obsluha** (viď strana 36)



## **Čistení** (viď strana 31) a priložená brožúra

Pri poklese prietoku vody vyčistiť filter umiestnený medzi hadicou a sifónom.



## **Osvedčenie o skúške** (viď strana 36)





## 安全技巧

△ 装配时为避免挤压和切割受伤，必须戴上手套。

△ 冷热水管间过大的压力差必须予以平衡。

## 安装提示

• 必须按照现行的规定安装，冲洗和测试产品！

## 技术参数

工作压力:	最大 1 MPa
推荐工作压力:	0,1 - 0,5 MPa
测试压强:	1,6 MPa
(1 MPa = 10 bar = 147 PSI)	
热水温度:	最大 80° C
推荐热水温度:	65° C
流量 钟0,3 MPa:	8 升/分钟
花洒出水流量:	10 升/分钟
bar水压下，水波器出水流量:	10 升/分钟
自动防止回流	

如果水压达到0,15 MPa以上，汉斯格雅双手柄龙头可以和液压式或热控式连续流热水器一起使用。



## 保养 (参见第 31 页)

单向阀必须在符合国家或当地的法律的情况下按照DIN EN 1717定期检查（至少一年一次）。



带有热水控制器的单手柄龙头的调节方法，参见第 34页。如果与连续流热水器一起使用，则不必作任何调节。



请勿使用含有乙酸的硅！



## 大小 (参见第 31 页)



## 备用零件 (参见第 35 页)



## 操作 (参见第 36 页)



## 清洗 (参见第 31 页) 并附有小手册

如果水流减少，清洁位于花洒头和软管之间的过滤网。



## 检验标记 (参见第 36 页)



安装 参见第 32 页



## Указания по технике безопасности

- ⚠ Во время монтажа следует надеть перчатки во избежание прищемления и порезов.
- ⚠ донного клапа. Перед установкой смесителя необходимо регулировочными кранами выровнять давление холодной и горячей воды при помощи вентилей регулирующих подачу воды в квартиру.

## Указания по монтажу

- Смеситель должен быть смонтирован по действующим нормам и в соответствии с настоящей инструкцией, проверен на герметичность и безупречность работы

## Технические данные

Рабочее давление:	не более. 1 МПа
Рекомендуемое рабочее давление:	0,1 - 0,5 МПа
Давление:	1,6 МПа
(1 МПа = 10 bar = 147 PSI)	
Температура горячей воды:	не более. 80 °С
Рекомендуемая темп. гор. воды:	65 °С
Расход при 0,3 МПа:	
Пропускная способность струи душа:	8 л/мин
Пропускная способность аэратора:	10 л/мин
укомплектован клапаном обратного тока воды	

Арматуры Hansgrohe могут использоваться в комбинации с проточными нагревателями с гидравлическим и термическим управлением, если давление истечения составляет не менее 0,15 МПа.



## Техническое обслуживание (см. стр. 31)

Защита обратного тока должна регулярно проверяться (минимум один раз в год) по стандарту DIN EN 1717 или в соответствии с национальными или региональными нормативами



Однорычажный смеситель имеет ограничитель расхода горячей воды (см. Стр. 34: юстировка).



Не применяйте силикон, содержащий уксусную кислоту.



## Размеры (см. стр. 31)



## Комплект (см. стр. 35)



## Эксплуатация (см. стр. 36)



## Очистка (см. стр. 31) и прилагаемая брошюра

При сокращенном расходе воды очистите грязеуловитель между ручным душем и шлангом.





## Знак технического контроля (см. стр. 36)





## Biztonsági utasítások

-  A szerelésnél a zúzódások és vágási sérülések elkerülése érdekében kesztyűt kell viselni.
-  A hidegvíz- és a melegvíz-csatlakozások közötti nagy nyomáskülönbséget kicell egyenlíteni!

## Szerelési utasítások

- A csaptelepet az érvényben lévő előírásoknak megfelelően kell felszerelni, átöblíteni és ellenőrizni!

## Műszaki adatok

Üzemi nyomás:	max. 1 MPa
Ajánlott üzemi nyomás:	0,1 - 0,5 MPa
Nyomáspróba:	1,6 MPa
(1 MPa = 10 bar = 147 PSI)	
Forróvíz hőmérséklet:	max. 80 °C
Forróvíz javasolt hőmérséklete:	65 °C
Átfolyási teljesítmény 0,3 MPa:	
Átfolyási teljesítmény, zuhanysugár:	8 l/perc
Átfolyási teljesítmény, perlátor:	10 l/perc
Visszafolyás gátlóval	

A Hansgrohe csaptelepek hidraulikus és termikus vezérlésű átfolyós melegítővel kapcsolatban is használhatóak, ha az átfolyó nyomás legalább 0,15 MPa.



## Karbantartás (lásd a 31. oldalon)

A visszafolyásgátlók működése a DIN EN 1717 szabványnak megfelelően, a nemzeti vagy területi rendelkezésekkel összhangban, évente egyszer ellenőrizendő!



Az egykaros, melegvíz-korlátozóval ellátott keverő csaptelep beállítását lásd a 34. oldalon. Az átfolyó rendszerű vízmelegítőknél nem szükséges a melegvíz-korlátozó.



Ne használjon ecetsavtartalmú szilikont!



## Méretet (lásd a 31. oldalon)



## Tartozékok (lásd a 35. oldalon)



## Használat (lásd a 36. oldalon)



## Tisztítás (lásd a 31. oldalon) és mellékelt brossúrával

Csökkent vízátérésztés esetén tisztítsa meg a kézi zuhany és a tömlő közti szennyfogó szűrőt.



## Vizsgajel (lásd a 36. oldalon)





## Turvallisuusohjeet

- ⚠ Asennuksessa on käytettävä käsineitä puristumien ja viiltojen aiheuttamien tapaturmien estämiseksi.
- ⚠ Suuret paine-erot kylmä- ja kuumavesiliitäntöjen välillä on tasattava.

## Asennusohjeet

- Kaluste on asennettava, huuhdeltava ja tarkastettava voimassa olevien määräysten mukaisesti!

## Tekniset tiedot

Käyttöpaine:	maks. 1 MPa
Suosittelut käyttöpaine:	0,1 - 0,5 MPa
Koestuspaine:	1,6 MPa
(1 MPa = 10 bar = 147 PSI)	
Kuuman veden lämpötila:	maks. 80 °C
Kuuman veden suosituslämpötila:	65 °C
Läpivirtausmäärä 0,3 MPa paineella:	
Läpivirtausmäärä:	8 l/min
Poresuuttimen läpivirtausmäärä:	10 l/min
Estää itsestään paluuvirtauksen	

Hansgrohe kalusteita voi käyttää hydraulisesti tai termisesti ohjattujen läpivirtauskuumentimien yhteydessä, jos virtauspaine on vähintään 0,15 MPa.



## Huolto (katso sivu 31)

Vastaventtiilien toiminta on tarkastettava säännöllisesti paikallisten ja kansallisten määräysten mukaisesti (DIN 1988, kerran vuodessa).



Yksivipuinen sekoittaja lämpimän veden rajoituksella, katso säätö sivulta 34. Lämpimän veden rajoitusta ei tarvita läpivirtauskuumentimen yhteydessä.



Älä käytä etikkahappopitoista silikonia!



## Mitat (katso sivu 31)



## Varaosat (katso sivu 35)



## Käyttö (katso sivu 36)



## Puhdistus (katso sivu 31) ja oheinen esite

Jos veden virtausmäärä pienenee, puhdista käsisuihkun ja letkun välissä oleva likasihti.





## Koestusmerkki (katso sivu 36)







## Säkerhetsanvisningar

-  Handskar ska bäras under monteringsarbetet så att man kan undvika kläm- och skärskadorgen werden.
-  Stora tryckskillnader mellan anslutningarna för varmt och kallt vatten måste utjämnas.

## Monteringsanvisningar

- Blandaren måste installeras, genomspolas och testas enligt gällande föreskrifter.

## Tekniska data

Driftstryck:	max. 1 MPa
Rek. driftstryck:	0,1 - 0,5 MPa
Tryck vid provtryckning:	1,6 MPa
(1 MPa = 10 bar = 147 PSI)	
Varmvattentemperatur:	max. 80 °C
Rek. varmvattentemp.:	65 °C
Flödeskapacitet vid 0,3 MPa:	
Flödeskapacitet duschstråle:	8 l/min
Genomströmningsskapacitet perlator:	10 l/min
Självspärr mot återflöde	

Hansgrohe blandare kan användas tillsammans med hydrauliskt och termiskt styrda varmvattenberedare när flödestrycket uppgår till minst 0,15 MPa.



## Skötsel (se sidan 31)

Backventilens funktion måste kontrolleras regelbundet enligt nationella eller regionala bestämmelser (DIN 1988 en gång per år) i enlighet med DIN EN 1717.



Enhandsblandare med varmvattenreglering, justering se sidan 34. Vid användning tillsammans med varmvattenberedare behövs ingen varmvattenreglering.



Använd inte silikon som innehåller ättiksyra!



## Måtten (se sidan 31)



## Reservdelar (se sidan 35)



## Hantering (se sidan 36)



## Rengöring (se sidan 31) och medföljande broschyr

Om vattenflödet minskar behöver smutsfiltret mellan handduschen och slangen göras ren.





## Testsigill (se sidan 36)





## Saugumo technikos nurodymai

 Apsaugai nuo užspaudimo ir įsijovavimo metu dėvėkite pirštines.

 Turi būti išlyginti šalto ir karšto slėgio nelygumai.

## Montavimo instrukcija

- Maišytuvą privalo būti montuojamas, išleidžiamas ir patikrinamas pagal galiojančias normas!

## Techniniai duomenys

Darbinis slėgis: ne daugiau kaip 1 MPa

Rekomenduojamas slėgis: 0,1 - 0,5 MPa

Bandomasis slėgis: 1,6 MPa

(1 MPa = 10 barų = 147 PSI)

Karšto vandens temperatūra: ne daugiau kaip 80 °C

Rekomenduojama karšto vandens temperatūra: 65 °C

Vandens pralaidumas, esant 0,3 MPa slėgiui:

Vandens pralaidumas. Dušo srovė: 8 l/min

Vandens pralaidumas. Oro kompresorius: 10 l/min

Su atbuliniu vožtuvu

„Hansgrohe“ maišytuvai gali būti naudojami su hidrauliškai ir termiškai reguliuojamais momentiniais šildikliais, kai vandens slėgis mažesnis kaip 0,15 MPa.



## Techninis aptarnavimas (žr. psl. 31)

Atbulinio vožtuvo apsauga privalo būti tikrinama reguliariai (mažiausiai kartą per metus pagal DIN 1988) pagal DIN EN1717 arba pagal galiojančias nacionalines arba regionines normas.



Vienos rankenėlės maišytuvą turi karšto vandens ribotuvą (nustatymą žr. psl. 34). Naudojant momentinį šildiklį karšto vandens ribotuvą nebūtina.



Nenaudokite silikono, kurio sudėtyje yra acto rūgšties!



## Išmatavimai (žr. psl. 31)



## Atsarginės dalys (žr. psl. 35)



## Eksplotacija (žr. psl. 36)



## Valymas (žr. psl. 31) ir pridėdama brošiūra

Jei sumažėja vandens slėgis, išvalykite filtrą, esantį tarp žarnos ir dušelio rankoms.



## Bandomo pažyma (žr. psl. 36)





## Sigurnosne upute

- ⚠ Prilikom montaže se radi sprječavanja prignječenja i posjekotina moraju nositi rukavice.
- ⚠ Velika razlika u pritisku između vruće i hladne vode mora biti izbalansirana.

## Upute za montažu

- Cijevi moraju biti postavljene, isprane i testirane prema važećim normama!

## Tehnički podaci

Najveći dopušteni tlak:	tlak 1 MPa
Preporučeni tlak:	0,1 - 0,5 MPa
Probni tlak:	1,6 MPa
(1 MPa = 10 bar = 147 PSI)	
Temperatura vruće vode:	tlak 80 °C
Preporučena temperatura vruće vode:	65 °C
Protok vode uz tlak od 0,3 MPa:	
Protočni mlaz:	8 l/min
Protok vode Prskanje:	10 l/min
Funkcije samo-čišćenja	

Hansgrohe armature mogu se koristiti u kombinaciji sa hidraulički i termički kontroliranim protočnim bojlerima ukoliko tlak iznosi najmanje 0,15 MPa



## Održavanje (pogledaj stranicu 31)

Ispravnost nepovratnog ventila mora se redovito provjeravati prema standardu DIN EN 1717 i u skladu sa važećim propisima (najmanje jednom godišnje).



Da bi podesili limiter vruće vode na jednoručnim slavinama molimo Vas da pogledate stranicu 34. Podešavanje nije potrebno ako koristite protočni bojler.



Nemojte koristiti silikon koji sadrži octenu kiselinu!



## Mjere (pogledaj stranicu 31)



## Rezervni djelovi (pogledaj stranicu 35)



## Upotreba (pogledaj stranicu 36)



## Čišćenje (pogledaj stranicu 31) i priložena brošura

Ukoliko ne izlazi dovoljno vode, moguće je da se na filteru između tuša i cijevi nakupila prljavština. Očistite filter.



## Oznaka testiranja (pogledaj stranicu 36)





## ⚠️ Güvenlik uyarıları

- ⚠️ Montaj esnasında ezilme ve kesilme gibi yaralanmaları önlemek için eldiven kullanılmalıdır.
- ⚠️ Sıcak ve soğuk su bağlantıları arasında büyük basınç farklılıkları varsa, bu basınç farklılıklarının dengelenmesi gerekir.

## Montaj açıklamaları

- Batarya geçerli normlara göre monte edilmeli, yıkanmalı ve kontrol edilmelidir!

## Teknik bilgiler

İşletme basıncı:	azami 1 MPa
Tavsiye edilen işletme basıncı:	0,1 - 0,5 MPa
Kontrol basıncı:	1,6 MPa
(1 MPa = 10 bar = 147 PSI)	
Sıcak su sıcaklığı:	azami 80 °C
Tavsiye edilen su ısısı:	65 °C
0,3 MPa'daki debi:	
Duş su akışındaki debi:	8 l/dak
Perlatörün debisi:	10 l/dak
Geri emme önleyici	

Hansgrohe bataryaları, akış basıncı en az 0,15 MPa olursa hidrolik ve termik kumandalı şofbenlerle bağlantılı olarak kullanılabilir.



## Bakım (Bakınız sayfa 31)

DIN EN 1717 ve ulusal standartlar doğrultusunda Çek valfler düzenli olarak kontrol edilmelidir. ( en az yılda bir kez)



Sıcak su sınırlayıcı özelliğine sahip tek kollu bataryanın ayarlanması için 34. sayfaya bakınız. Bir sürekli akışlı su ısıtıcısı ile birlikte kullanılırsa sıcak su sınırlayıcısına gerek kalmaz.



Asetik asit içeren silikon kullanmayın!



## Ölçüleri (Bakınız sayfa 31)



## Yedek Parçalar (Bakınız sayfa 35)



## Kullanımı (Bakınız sayfa 36)



## Temizleme (Bakınız sayfa 31) ve birlikte verilen broşür

Su debisinin azalması durumunda, el duşu ve hortum arasındaki filtreyi temizleyin.





## Kontrol işareti (Bakınız sayfa 36)





## Instrucțiuni de siguranță

-  La montare utilizați mănuși pentru evitarea contuziunilor și tăierii mâinilor.
-  Diferențele de presiune mari între alimentarea cu apă rece și apă caldă trebuie echilibrate.

## Instrucțiuni de montare

- Bateria trebuie montată, clătită și verificată conform normelor în vigoare.

## Date tehnice

Presiune de funcționare:	max. 1 MPa
Presiune de funcționare recomandată:	0,1 - 0,5 MPa
Presiune de verificare:	1,6 MPa
(1 MPa = 10 bar = 147 PSI)	
Temperatura apei calde:	max. 80 °C
Temperatura recomandată a apei calde:	65 °C
Debit de apă la 0,3 MPa:	
Debitul de apă al dușului stropitor:	8 l/min
Debitul de apă al pulverizatorului de aer:	10 l/min
Asigurat contra scurgere înapoi	

Bateriile Hansgrohe pot fi utilizate cu boiler instant cu comandă termică sau hidraulică dacă presiunea apei de alimentare este de min. 0,15 MPa.



## Întreținere (vezi pag. 31)

Supapele de reținere trebuie verificate regulat conform DIN EN 1717 și standardele naționale sau regionale (anual conform DIN 1988).



Bateria monocomadă cu limitarea apei calde, pentru reglare vezi pag. 34. Dacă conectați bateria la un boiler instant nu este necesară instalarea unui opritor de apă caldă.



Nu utilizați silicon cu conținut de acid acetic!



## Dimensiuni (vezi pag. 31)



## Piese de schimb (vezi pag. 35)



## Utilizare (vezi pag. 36)



## Curățare (vezi pag. 31) și broșura alăturată

În cazul unui debit redus de apă, curățați sита de impurități dintre capătul de duș și furtun.





## Certificat de testare (vezi pag. 36)





## Υποδειξεις ασφαλείας

-  Για να αποφύγετε τραυματισμούς κατά τη συναρμολόγηση πρέπει να φοράτε γάντια.
-  Οι διαφορές της πίεσης μεταξύ της σύνδεσης κρύου και ζεστού νερού θα πρέπει να αντισταθμίζονται.

## Οδηγίες συναρμολόγησης

- Η κεντρική βάνα πρέπει να τοποθετηθεί, να πλυθεί και να ελεγχθεί με βάση τους ισχύοντες κανόνες υδραυλικής τέχνης!

## Τεχνικά Χαρακτηριστικά

Λειτουργία πίεσης:	έως 1 MPa
Συνιστώμενη λειτουργία πίεσης:	0,1 - 0,5 MPa
Πίεση ελέγχου:	1,6 MPa
(1 MPa = 10 bar = 147 PSI)	
Θερμοκρασία ζεστού νερού:	έως 80 °C
Συνιστώμενη θερμοκρασία ζεστού νερού:	65 °C
Κατανάλωση νερού στα 0,3 MPa:	
Κατανάλωση νερού σε δέσμη καταιονισμού στα	8 l/min
Κατανάλωση νερού στο φίλτρο:	10 l/min
Περιλαμβάνει βαλβίδα αντεπιστροφής.	

Οι βάνες Hansgrohe μπορούν να συνδυαστούν με ταχυθερμοσίφωνες υδραυλικού και θερμικού ελέγχου, όταν η πίεση ροής αριθμεί τουλάχιστον 0,15 MPa.



## Συντήρηση (βλ. σελίδα 31)

Οι βαλβίδες αντεπιστροφής πρέπει να ελέγχονται τακτικά ως προς τη λειτουργία τους, σύμφωνα με τις οδηγίες DIN EN 1717, σε σχέση με τους ισχύοντες εθνικούς ή τοπικούς κανόνες (το ελάχιστο μια φορά το χρόνο, σύμφωνα με το πρότυπο DIN 1988)



Για να προσαρμόσετε το δοσομετρητή ζεστού νερού σε αναμεικτικές μπαταρίες, παρακαλούμε δείτε τη ρύθμιση στη σελ. 34. Δεν είναι απαραίτητη η διάταξη φραγής ζεστού νερού σε συνδυασμό με ταχυθερμοσίφωνα.

Μην χρησιμοποιείτε σιλικόνη που περιέχει οξικό οξύ!



## Διαστάσεις (βλ. σελίδα 31)



## Ανταλλακτικά ( βλ. σελίδα 35 )



## Χειρισμός (βλ. σελίδα 36)



## Καθαρισμός (βλ. σελίδα 31) και συνημμένο φυλλάδιο

Σε μειωμένη ροή νερού, καθαρίστε τα φίλτρο συλλογής ακαθαρσιών, που βρίσκεται ανάμεσα στον καταιονιστήρα χειρός και στο σωλήνα παροχής.





## Σήμα ελέγχου (βλ. σελίδα 36)





## Varnostna opozorila

-  Pri montaži je treba nositi rokavice, da se preprečijo poškodbe zaradi zmečkanja ali urezov.
-  Velike razlike v tlaku med priključkom za mrzlo in priključkom za toplo vodo je potrebno izravnati.

## Navodila za montažo

- La robinetterie doit être installée, rincée et contrôlée conformément aux normes valables!

## Tehnični podatki

Delovni tlak:	maks. 1 MPa
Priporočeni delovni tlak:	0,1 - 0,5 MPa
Preskusni tlak:	1,6 MPa
(1 MPa = 10 bar = 147 PSI)	
Temperatura tople vode:	maks. 80 °C
Priporočena temperatura tople vode:	65 °C
Pretok vode pri 0,3 MPa:	
Pretok vode curek prhe:	8 l/min
Pretok vode curek perlatorja:	10 l/min
Zaščita proti povratnemu toku	

Armature Hansgrohe lahko uporabljate v povezavi s hidravlično in termično uravnanimi pretočnimi grelniki, če je pretočni tlak najmanj 0,15 MPa.



## Vzdrževanje (glejte stran 31)

Delovanje protipovratnega ventila je potrebno v skladu z DIN EN 1717 in skladno z državnimi in regionalnimi določili (DIN 1988 enkrat letno) redno testirati.



Enoročne mešalne baterije z omejevalnikom tople vode, za justiranje glejte stran 34. V povezavi s pretočnimi grelniki zapora tople vode ni potrebna.



Ne smete uporabiti silikona, ki vsebuje ocatno kislino!



## Mere (glejte stran 31)



## Rezervni deli (glejte stran 35)



## Upravljanje (glejte stran 36)



## Čiščenje (glejte stran 31) in priložena brošura

Ob zmanjšanem pretoku vode očistite filter med ročno prho in gibko cevjo.





## Preskusni znak (glejte stran 36)



**Montaža Glejte stran 32.**



## Ohutusjuhised

-  Kandke paigaldamisel muljumis- ja löikevigastuste vältimiseks kindaid.
-  Kui külma ja kuuma vee ühenduste surve on väga erinev, tuleb need tasakaalustada.

## Paigaldamisjuhised

- Segisti paigaldamine, loputamine ja kontroll peab toimuma vastavalt kehtivatele normidele!

## Tehnilised andmed

Töörõhk	maks. 1 MPa
Soovitatav töörõhk:	0,1 - 0,5 MPa
Kontrollsurve:	1,6 MPa
(1 MPa = 10 baari = 147 PSI)	
Kuuma vee temperatuur:	maks. 80 °C
Soovitatav kuuma vee temperatuur:	65 °C
Läbivool, kui rõhk on 0,3 MPa:	
Duši läbivool:	8 l/min
Läbivool õhustatuse korral:	10 l/min
tagasivooluklapp	

Hansgrohe segisteid võib kasutada koos hüdrauliliselt ja termiliselt juhitavate boileritega, kui vee surve on vähemalt 0,15 MPa.



## Hooldus (vt lk 31)

Tagasilöögiklappide toimimist tuleb kooskõlas riiklike ja regionaalsete määrustega regulaarselt kontrollida vastavalt standardile DIN EN 1717 (DIN 1988 - kord aastas).



Ühe juhtkangiga segisti kuuma vee piiraja reguleerimise kohta vt lk 34. Läbivoolu boilerite puhul pole reguleerimine vajalik.



Ärge kasutage äädikhapet sisaldavat silikooni!



## Mõõtude (vt lk 31)



## Varuosad (vt lk 35)



## Kasutamine (vt lk 36)



## Puhastamine (vt lk 31) ja kaasasolev brošüür

Kui vee läbivool on vähenenud, puhastage ära käsiduši ja vooliku vaheline filter.





## Kontrollsertifikaat (vt lk 36)







## Drošības norādes

-  Montāžas laikā, lai izvairītos no saspiedumiem un iegriezumiem, nepieciešams nēsāt cimdus.
-  Jāizlīdzina spiediena atšķirības starp aukstā un karstā ūdens pievadiem.

## Norādījumi montāžai

- Armatūra jāuzstāda, jāizskalo un jāpārbauda atbilstoši spēkā esošajām normām!

## Tehniskie dati

Darba spiediens:	maks. 1 MPa
leteicamais darba spiediens:	0,1 - 0,5 MPa
Pārbaudes spiediens:	1,6 MPa
(1 MPa = 10 bar = 147 PSI)	
Karstā ūdens temperatūra:	maks. 80 °C
leteicamā karstā ūdens temperatūra:	65 °C
Caurteces intensitāte pie 0,3 MPa:	
Caurteces intensitāte dušas strūklai:	8 l/min
Caurteces intensitāte gaisa strūklai:	10 l/min
Drošības vārsts	

Hansgrohe jaucējkrānus var izmantot kombinācijā ar hidrauliski un termiski vadāmiem caurteces sildītājiem, ja plūsmas spiediens ir vismaz 0,15 MPa.



## Apkope (skat. 31. lpp.)

Regulāri jāpārbauda pretvārsta funkcija saskaņā ar DIN EN 1717 saistībā ar nacionālajiem vai vietējiem noteikumiem (DIN 1988 vienreiz gadā).



Viensvires jaucējkrāns ar siltā ūdens ierobežošanu, ieregulēšanu skat. 34. lpp. Kombinācijā ar caurteces sildītāju karstā ūdens ierobežošana nav nepieciešama.



Neizmantojiet silikonu, kas satur etiķskābi!



## Izmērus (skat. 31. lpp.)



## Rezerves daļas (skat. 35. lpp.)



## Lietošana (skat. 36. lpp.)



## Tīrīšana (skat. 31. lpp.) un klāt pievienotais buklets

Nepietiekamas ūdens plūsmas gadījumā jāiztīra filtrs, kas atrodas starp rokas dušu un šļūteni



## Pārbaudes zīme (skat. 36. lpp.)





## Sigurnosne napomene

- ⚠ Prilikom montaže se radi sprečavanja prignječenja i posekotina moraju nositi rukavice.
- ⚠ Velika razlika u pritisku između vruće i hladne vode mora biti izbalansirana.

## Instrukcije za montažu

- Armatura mora biti postavljena, isprana i testirana prema važećim normama!

## Tehnički podaci

Radni pritisak:	maks. 1 MPa
Preporučeni radni pritisak:	0,1 - 0,5 MPa
Probni pritisak:	1,6 MPa
(1 MPa = 10 bar = 147 PSI)	
Temperatura vruće vode:	maks. 80 °C
Preporučena temperatura vruće vode:	65 °C
Protok vode pri pritisku od 0,3 MPa:	
Protočni mlaz:	8 l/min
Protok vode aerator:	10 l/min
Zaštita od povratnog toka	

Hansgrohe armature se mogu koristiti u kombinaciji s hidraulički i termički kontrolisanim protočnim bojlerima ukoliko pritisak iznosi najmanje 0,15 MPa.



## Održavanje (vidi stranu 31)

Ispravno funkcionisanje nepovratnog ventila se mora redovno proveravati prema standardu DIN EN 1717 i u skladu s važećim nacionalnim ili regionalnim propisima (DIN 1988 jednom godišnje).



Da bi ste podesili ograničavač vruće vode na jednoručnim mešačima, molimo Vas da pogledate stranicu 34. Podešavanje nije potrebno ako koristite protočni bojler.



Nemojte koristiti silikon koji sadrži sirćetnu kiselinu!



## Mere (vidi stranu 31)



## Rezervni delovi (vidi stranu 35)



## Rukovanje (vidi stranu 36)



## Čišćenje (vidi stranu 31) i priložena brošura

Ukoliko ne izlazi dovoljno vode, moguće je da se na mrežici za hvatanje prljavštine, između glave i creva tuša, nakupila prljavština. Očistite filter.





## Ispitni znak (vidi stranu 36)





## Sikkerhetshenvisninger

-  Bruk hansker under montasjen for å unngå klem- og kuttskader.
-  Store trykkdifferanser mellom kaldt- og varmtvannstilkoblinger skal utlignes.

## Montagehenvisninger

- Armaturen skal monteres iht. gyldige standarder. De skal spyles og sjekkes!

## Tekniske data

Driftstrykk	maks. 1 MPa
Anbefalt driftstrykk:	0,1 - 0,5 MPa
Prøvetrykk	1,6 MPa
(1 MPa = 10 bar = 147 PSI)	
Varmtvannstemperatur	maks. 80 °C
Anbefalt temperatur for varmt vann	65 °C
Gjennomstrømningsytelse ved 0,3 MPa:	
Gjennomstrømningsytelse dusjstråle:	8 l/min
Gjennomstrømningsytelse luftsprudler:	10 l/min
Egensikker mot tilbakeflyt	

Armaturer fra Hansgrohe kan brukes sammen med hydraulisk og termisk styrte gjennomstrømningsovner når gjennomstrømningstrykket er på minst 0,15 MPa.



## Vedlikehold (se side 31)

Funksjonen til returløpssperren skal iht. DIN EN 1717 og i samsvar med de nasjonale og lokale forskrifter sjekkes regelmessig (DIN 1988 en gang i året).



Enhåndblanderbatteri med varmtvannsbegrensning. For justering se side 34. I forbindelse med en gjennomstrømningsovn er det ikke nødvendig med varmtvannsbegrensning.



Ikke bruk silikon som inneholder eddiksyre!



## Mål (se side 31)



## Serviceledere (se side 35)



## Betjening (se side 36)



## Rengjøring (se side 31) og vedlagt brosjyre

Ved forminsknet vanngjennomstrømning skal smussfilteret mellom hånddusj og slangen renses.



## Prøvemerket (se side 36)



**Montasje se side 32**



## Указания за безопасност

- ⚠ При монтажа трябва да се носят ръкавици, за да се избегнат наранявания поради притискане или порязване.
- ⚠ Големите разлики в налягането между изводите за студената и топлата вода трябва да се изравняват.

## Указания за монтаж

- Арматурата трябва да се монтира, промие и провери в съответствие с валидните норми!

## Технически данни

Работно налягане:	макс. 1 МПа
Препоръчително работно налягане:	0,1 - 0,5 МПа
Контролно налягане:	1,6 МПа
(1 МПа = 10 bar = 147 PSI)	
Температура на горещата вода:	макс. 80 °C
Препоръчителна температура на горещата вода:	65 °C
Мощност на потока при 0,3 МПа:	
Мощност на потока разпръскваща струя:	8 л/мин
Мощност на потока аератор:	10 л/мин
Самозащитен против обратно изтичане	

Арматурите на Hansgrohe могат да се използват във връзка с хидравлично и термично управляеми проточни нагреватели, ако хидравличното налягане е минимум 0,15 МПа.



## Поддръжка (вижте стр. 31)

Съгласно DIN EN 1717 редовно трябва да се проверява функционирането на приспособленията за предотвратяване на обратния поток в съответствие с националните или регионални изисквания (DIN 1988 веднъж годишно).



Смесител с една ръкохватка с ограничител за топлата вода, юстирането вижте на стр. 34. Във връзка с проточни нагреватели не е необходима блокировка за топлата вода.



Не използвайте силикон, съдържащ оцетна киселина!



## Размери (вижте стр. 31)



## Сервизни части (вижте стр. 35)



## Обслужване (вижте стр. 36)



## Почистване (вижте стр. 31) и приложена брошура

При намалена пропускателна способност на водата почистете цедката за улавяне на замърсявания между изтеглящия се разпръсквател за кухненската мивка и маркуча.





## Контролен знак (вижте стр. 36)





## Udhëzime sigurie

-  Për të evituar lëndimet e pickimeve ose të prerjeve gjatë procesit të montimit duhet që të vishni doreza.
-  Ndryshimet e mëdha të presionit mes lidhjeve të ujit të ftohtë dhe atij të ngrohtë duhen ekuilibruar.

## Udhëzime për montimin

- Armatura duhet montuar, shpërlarë dhe kontrolluar në bazë të normave të vlefshme!

## Të dhëna teknike

Presioni gjatë punës	maks. 1 MPa
Presioni i rekomanduar:	0,1 - 0,5 MPa
Presioni për provë:	1,6 MPa
(1 MPa = 10 bar = 147 PSI)	
Temperatura e ujit të ngrohtë	maks. 80 °C
Temperatura e rekomanduar e ujit të ngrohtë:	65 °C
Kapaciteti i rrjedhjes në 0,3 MPa:	
Kapaciteti i rrjedhjes në currilit të spërkatëses:	8 l/min
Kapaciteti i rrjedhjes së perlatorit:	10 l/min
Siguresa kundër rrjedhjes në drejtim të kundërt	

Armaturat e Hansgrohe mund të përdoren në kombinim me ngrohës elektrikë të ujit të drejtuar në mënyrë hidraulike ose termike nëse presioni i rrjedhjes është minimumi 0,15 MPa.



## Mirëmbajtja (shih faqen 31)

Penguesit e rrjedhjes në drejtim të kundërt duhen kontrolluar rregullisht në bazë të normave DIN EN 1717 konform normave nacionale dhe regionale (DIN 1988 një herë në vit).



Rubinet me ujë të përzier me kufizim të ujit të ngrohtë, justimi shih faqen 34. Në kombinim me ngrohësit elektrikë të ujit nuk ka nevojë për bllokadë të ujit të ngrohtë.



Mos përdorni silikon që në përbërje ka acid acetik.



## Përmasat (shih faqen 31)



## Pjesë ndërrimi (shih faqen 35)



## Përdorimi (shih faqen 36)



## Pastrimi (shih faqen 31) dhe broshura bashkëngjitur

Nëse pakësohet vëllimi i ujit, atëherë pastroni sitën për mbledhjen e ndotjeve që ndodhet mes spërkatëses në formë grushti dhe tubit.



## Shenja e kontrollit (shih faqen 36)





### الصيانة (راجع صفحة 31)

يجب فحص صمام عدم الرجوع بصفة منتظمة حسب المواصفة DIN EN 1717 وذلك طبقاً للوائح الوطنية أو الإقليمية (مرة واحد سنوياً طبقاً للمواصفة DIN 1988).



لضبط محدد الماء الساخن في الخلاطات ذات المقبض الواحد، يرجى الرجوع إلى صفحة 34. ولا يلزم إجراء أي ضبط عند استخدام سخان مياه ذي تدفق مستمر.



هام! لا تستخدم السليكون الذي يحتوي على أحماض!

### أبعاد (راجع صفحة 31)



### قطع الغيار (راجع صفحة 35)



### التشغيل (راجع صفحة 36)



### التنظيف (راجع صفحة 31) والكتيب المرفق

إذا انخفض معدل تدفق المياه، قم بتنظيف المرشح (الفلتر) الموجود بين الخرطوم والرشاش اليدوي.



### شهادة اختبار (راجع صفحة 36)



### تنبيهات الأمان



⚠ يجب إرتداء قفازات لليد أثناء التركيب لتجنب حدوث أضرار الإنحشار أو الجروح.

⚠ يجب أن يكون تيار الماء الساخن والماء البارد متعادلين في الضغط.

### تعليمات التركيب

يجب تركيب الوصلة، وغمرها بالماء واختبارها وفقاً للمعايير السارية! **المواصفات الفنية**

ضغط التشغيل: الحد الأقصى 1 ميجاباسكال  
ضغط التشغيل الموصى به: 0,1 - 0,5 ميجاباسكال  
ضغط الاختبار: 1,6 ميجاباسكال

(1 ميجاباسكال = 10 بار = 147 PSI)

درجة حرارة الماء الساخن: الحد الأقصى 80°C  
درجة الحرارة الموصى بها للماء الساخن: 65°C

معدل التدفق عند ضغط 0,3 ميجاباسكال:

قدرة تدفق الماء من الدش: 8 لتر / الدقيقة  
قدرة التدفق من تجهيزة التهوية (تجهيزة توزيع المياه): 10 لتر / الدقيقة  
خاصية عدم التدفق العكسي

يمكن استخدام خلاطات هانزجرهوي مع سخانات تدفق الماء ذات التحكم الهيدروليكي و الحراري، مع ضغط تدفق لا يقل عن 0,15 ميجاباسكال.



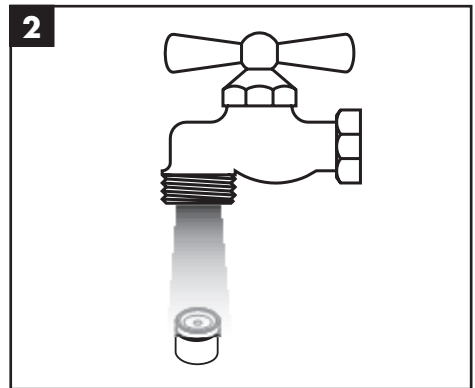
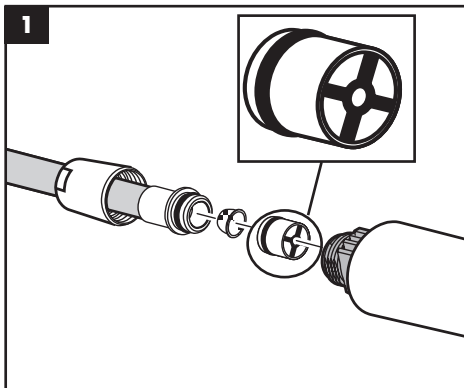
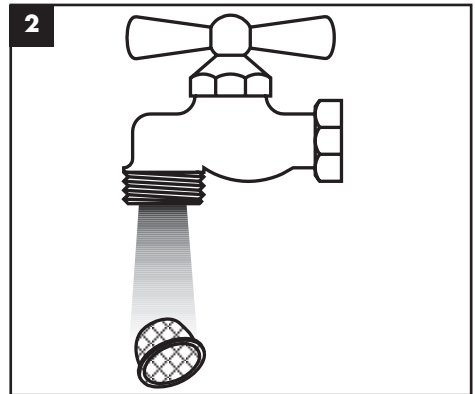
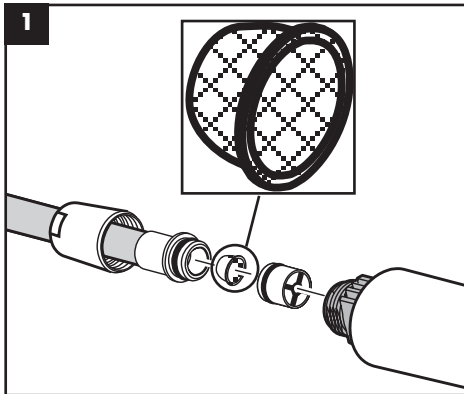
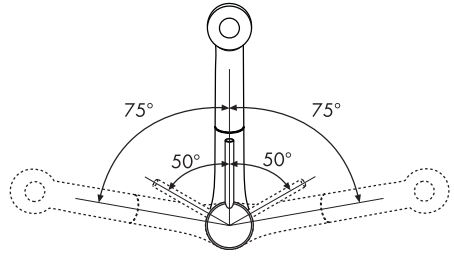
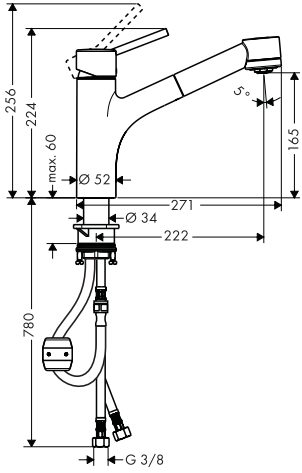
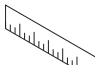

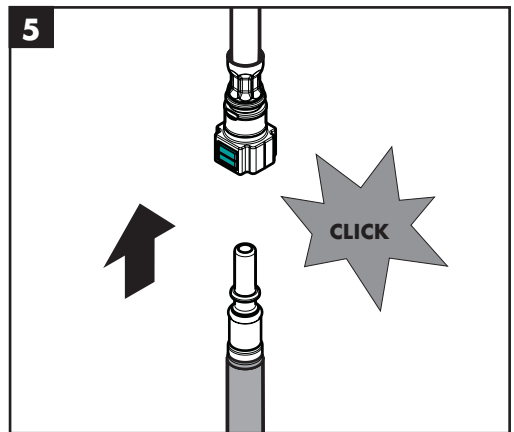
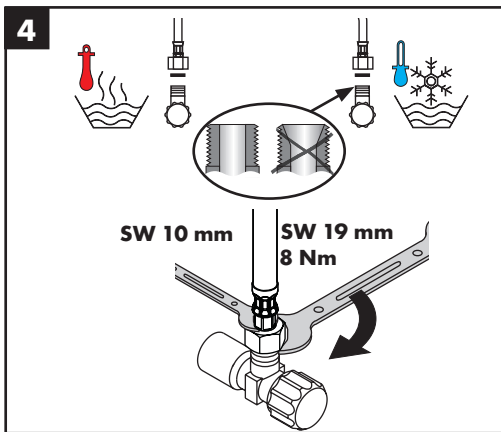
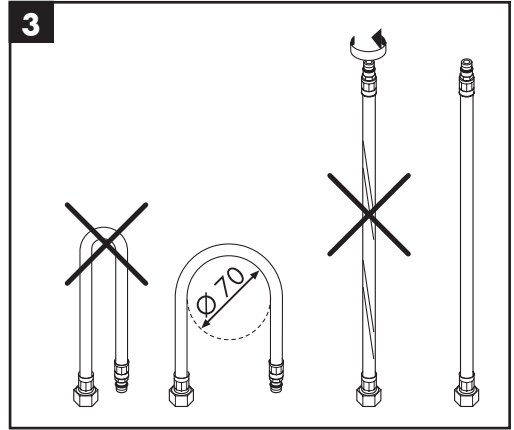
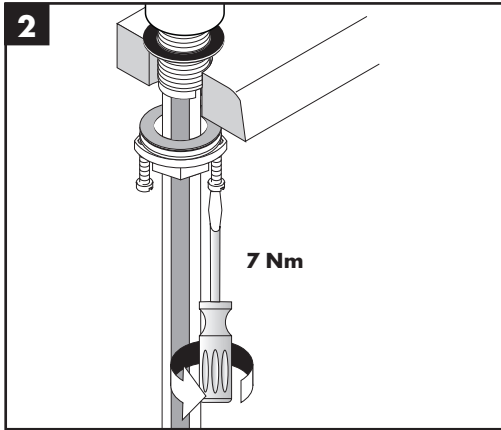
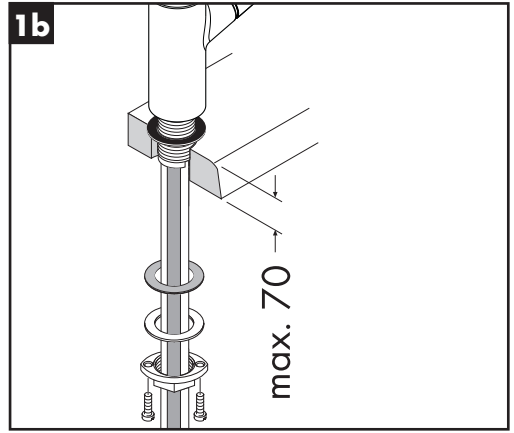
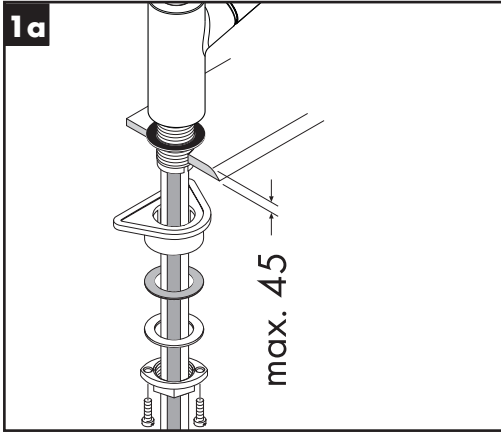



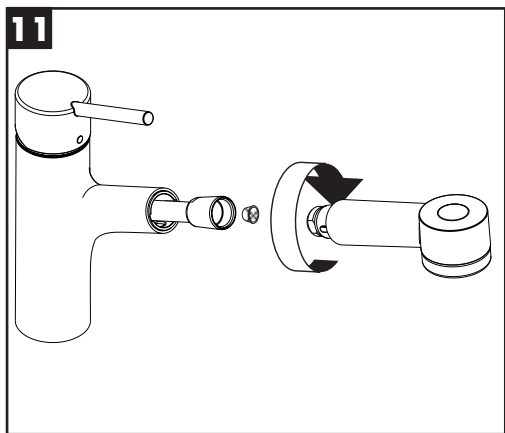
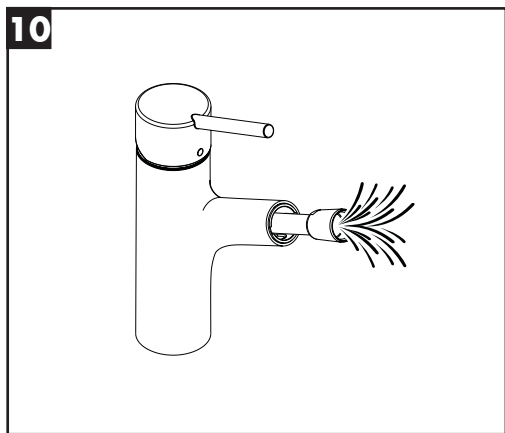
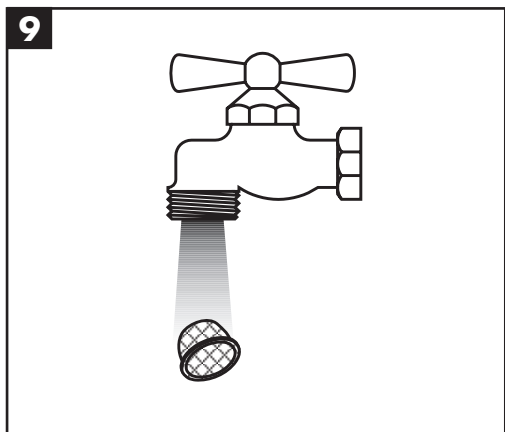
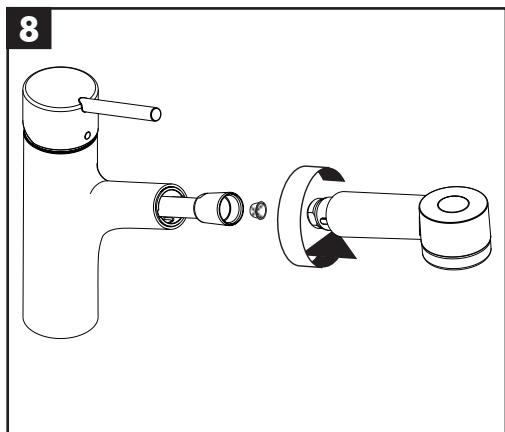
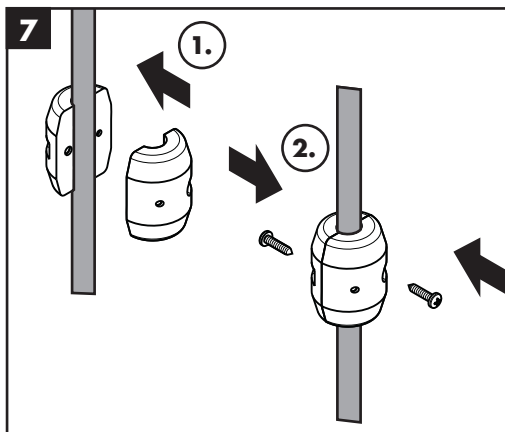
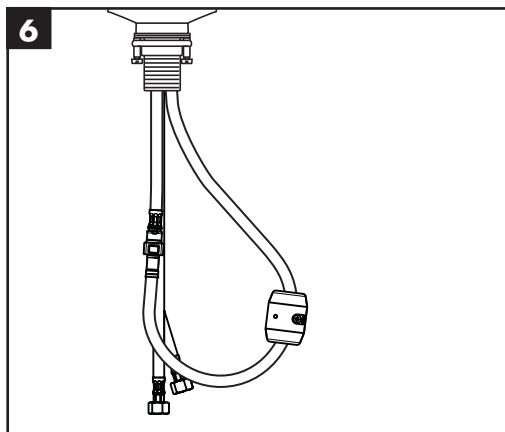



60 °C



10 °C



0,3 MPa  
0,3 MPa  
میجابسکال

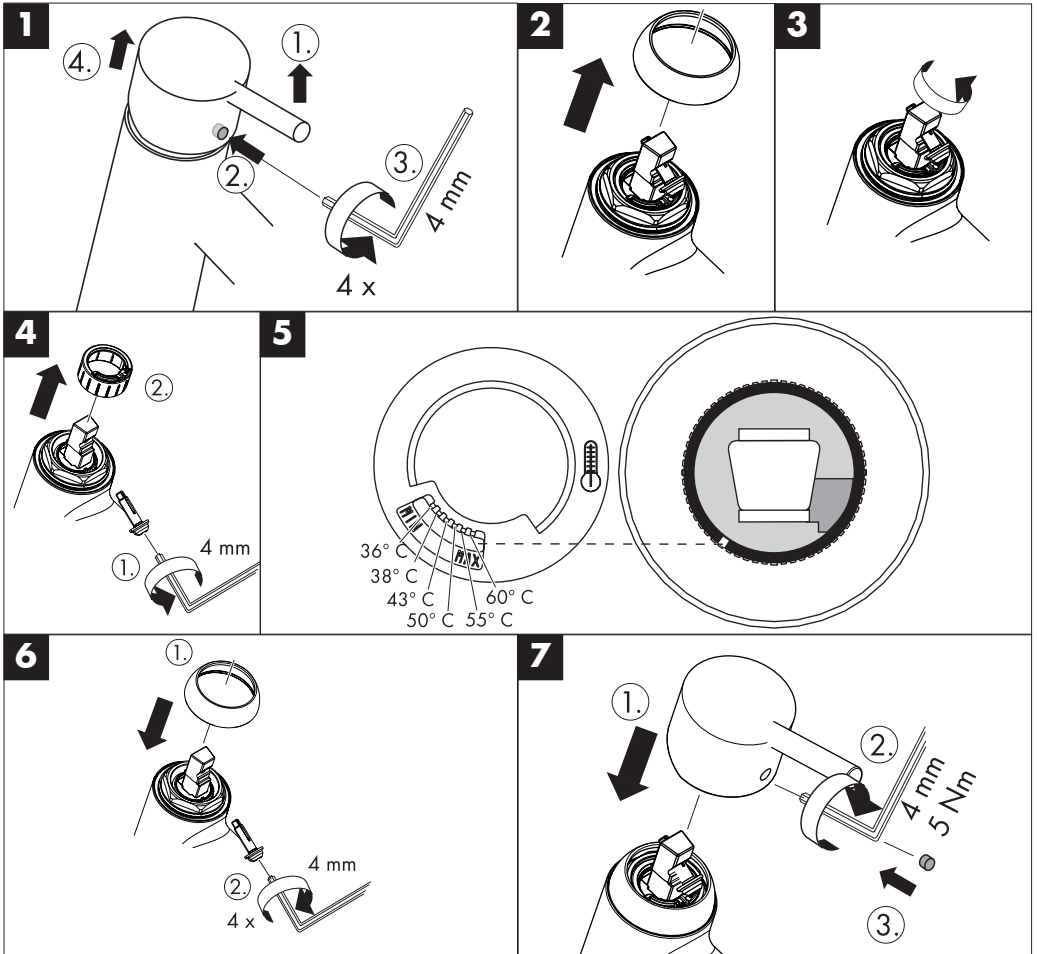

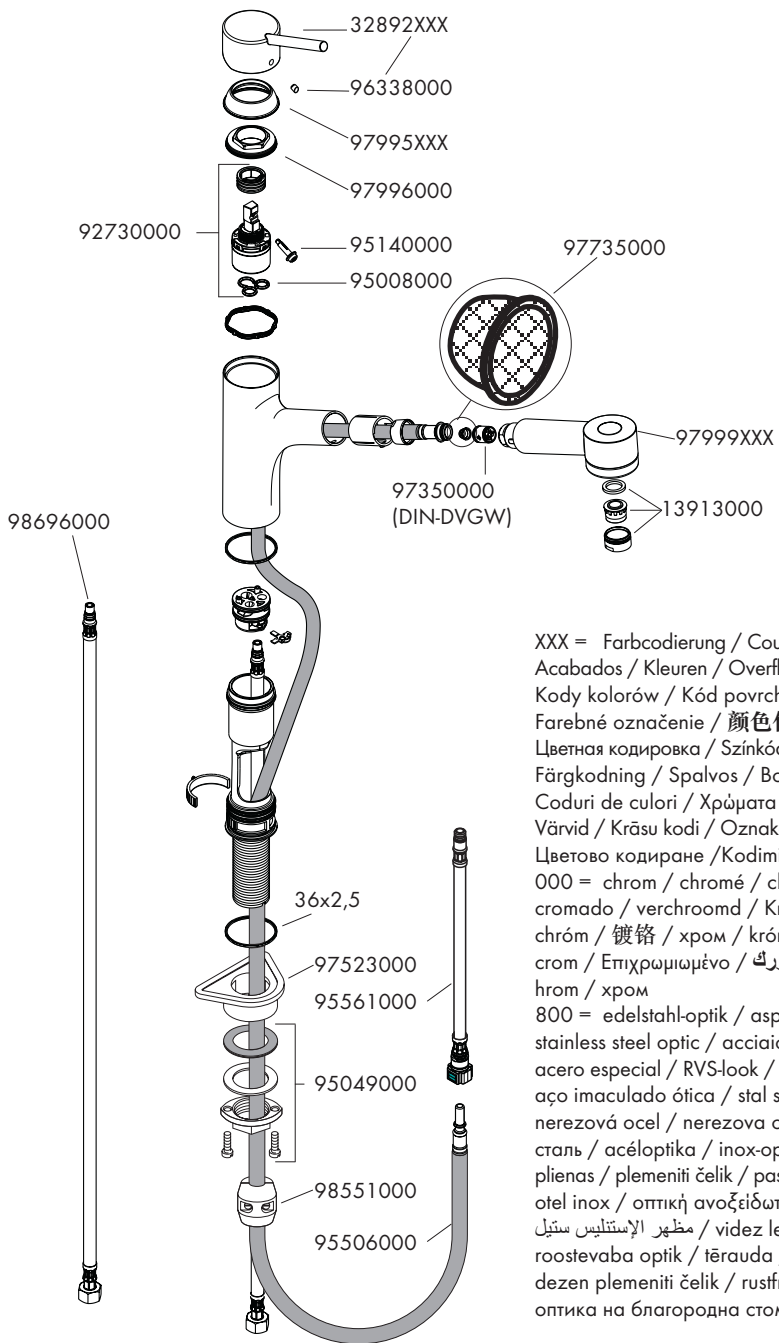

XXX = Farbcodierung / Couleurs / Colors / Trattamento /  
 Acabados / Kleuren / Overflade / Acabamentos /  
 Kody kolorów / Kód povrchové úpravy /  
 Farebné označenie / 颜色代码 /  
 Цветная кодировка / Színkódolás / Värnikoodaus /  
 Färgkodning / Spalvos / Boje / Renkler /  
 Coduri de culori / Χρώματα / ناول ألوان / Barve /  
 Värvid / Krāsu kodi / Označe boja / Fargekode /  
 Цветово кодиране / Kodimi me anë të ngjyrave  
 000 = chrom / chromé / chrome plated / cromato /  
 cromado / verchromd / Krom / cromado /  
 chróm / 镀铬 / хром / króm / kromi / krom /  
 crom / Επιχρωμωμένο / مورك / kroom / hroma /  
 hrom / хром  
 800 = edelstahl-optik / aspect acier inox /  
 stainless steel optic / acciaio inox acciaio /  
 acero especial / RVS-look / Stainless steel optic /  
 aço imaculado ótica / stal szlachetna /  
 nerezová ocel / nerezova ocel / 不锈钢表面 /  
 сталь / acéloptika / inox-optinen / rostfri-optik /  
 plienas / plemeniti čelik / paslanmaz çelik - optik /  
 otel inox / οπτική ανοξείδωτου χάλυβα /  
 مظہر الستانلیس ستیل / videz legiranega jekla /  
 roostevaba optik / tërauda /  
 dezen plemeniti čelik / rustfritt stål optikk /  
 оптика на благородна стомана / optikë çeliku

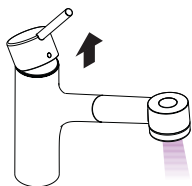

öffnen / ouvert / open / aperto / abierto / open / åbne /  
 abrir / otworzyć / otevřít / otvorit / 开 / открыть / nyitás /  
 avaaaminen / öppna / atidaryti / Otvaranje / açmak /  
 deschide / ανοικτό / فتح / odpreti / avage / atvērt /  
 otvoriti / åpne / отварање / hare

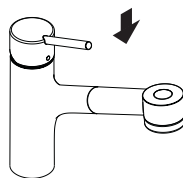

schließen / fermé / close / chiudere / cerrar / sluiten /  
 lukke / fechar / zamknąć / zavřít / uzavriť / 关 /  
 закрыть / bezárás / sulkeminen / stänga / uždaryti /  
 Zatvaranje / karatmak / închide / κλειστό / إغلاق /  
 zapreti / sulgege / aizvērt / zatvori / lukke / затваряне /  
 mbylle

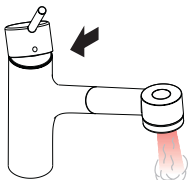

warm / chaud / hot / caldo / caliente / warm / varmt /  
 quente / ciepła / teplá / teplá / 热 / горячая / meleg /  
 lämmin / varmt / karštas / Vruća voda / sıcak / cald /  
 ζεστό / ساخن / toplo / kuum / karsts / topla / varm /  
 тепло / i ngrohtë

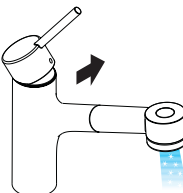

kalt / froid / cold / freddo / frío / koud / koldt / fria /  
 zimna / studená / studená / 冷 / холодная / hideg /  
 kylmä / kallt / šaltas / Hladno / soğuk / rece / krúo /  
 بارد / mrzlo / külm / auksts / hladno / kaldt / студено /  
 i ftohtë

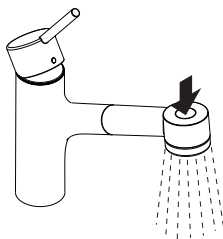

	P-IX	DVGW	SVGW	ACS	WRAS	ETA	KIWA	NF
<b>32841XXX</b>	P-IX 18333/IBO		X	X	X	1.42/19670	X	
<b>32843000</b>	P-IX 18333/IBO			X	X			

