

Installation Manual

Montageanleitung
Instructions de montage
Istruzioni per il montaggio

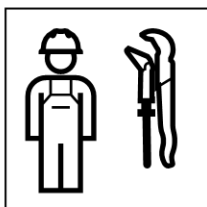



WARNING

Augenverletzung und Schnittverletzung durch Glassplitter

- ▶ Schutzbrille tragen
- ▶ Schnittfeste Handschuhe tragen
- ▶ Glaskanten und -flächen vor Beschädigungen schützen
- ▶ Glasplatte gegen Umfallen sichern
- ▶ Nur unbeschädigte Komponenten verarbeiten
- ▶ Befestigungsrahmen ohne mechanischen Verzug montieren, um Spannungen der Glasplatte zu verhindern



WARNING

Eye damage and cuts from glass fragments

- ▶ Wear protective goggles
- ▶ Wear cut-resistant gloves
- ▶ Protect glass edges and surfaces against damage
- ▶ Secure the glass plate against falling
- ▶ Only process components that are not damaged
- ▶ Mount the mounting frame without mechanical distortion to prevent tension on the glass plate



AVERTISSEMENT

Risque de blessure. Des éclats de verre peuvent atteindre les yeux ou causer des coupures

- ▶ Porter des lunettes de protection
- ▶ Porter des gants anticoupure
- ▶ Protéger les arêtes et les surfaces en verre contre les dommages
- ▶ Sécuriser la plaque en verre pour l'empêcher de basculer
- ▶ N'installer que des composants non endommagés
- ▶ Monter le cadre de fixation sans distorsion mécanique afin d'éviter tout gauchissement de la plaque en verre



AVVERTENZA

Lesioni agli occhi e da taglio a causa di schegge di vetro

- ▶ Indossare occhiali di protezione
- ▶ Indossare guanti antitaglio
- ▶ Proteggere dai danni i bordi e le superfici in vetro
- ▶ Fissare adeguatamente la lastra di vetro per evitarne la caduta
- ▶ Lavorare solo componenti integri
- ▶ Montare il telaio di fissaggio senza distorsione meccanica, per evitare deformazioni della lastra di vetro



WAARSCHUWING

Oogletsel en snijwonden door glassplinters

- ▶ Beschermbril dragen
- ▶ Snijvaste handschoenen dragen
- ▶ Glasranden en glasoppervlakken beschermen tegen beschadiging
- ▶ Glasplaat beveiligen tegen omvallen
- ▶ Alleen onbeschadigde componenten verwerken
- ▶ Montageframe zonder mechanische kromtrekking monteren om spanning in de glasplaat te vermijden



ADVERTENCIA

Lesiones en los ojos y por cortes por esquirlas de vidrio

- ▶ Utilizar unas gafas de protección
- ▶ Utilizar unos guantes a prueba de cortes
- ▶ Proteger los bordes y superficies de vidrio frente a daños
- ▶ Asegurar la placa de vidrio frente a caídas
- ▶ Trabajar únicamente componentes libres de daños
- ▶ Montar el marco de fijación sin estiraje mecánico para evitar deformaciones en la placa de vidrio



ATENÇÃO

Lesão ocular e perigo de corte devido a estilhaços de vidro

- ▶ Utilizar óculos de proteção
- ▶ Utilizar luvas de proteção resistentes
- ▶ Proteger as bordas e as superfícies de vidro contra danos
- ▶ Fixar a placa de vidro contra quedas
- ▶ Processar apenas componentes não danificados
- ▶ Montar o aro de fixação sem estiragem mecânica para evitar tensões na placa de vidro



ADVARSEL

Øjenskader og snitsår på grund af glassplinter

- ▶ Brug beskyttelsesbriller
- ▶ Bær skærefaste handsker
- ▶ Beskyt glaskanter og -flader mod skader
- ▶ Sørg for, at glaspladen ikke kan vælte
- ▶ Forarbejd kun intakte komponenter
- ▶ Monter monteregerammen uden mekanisk forskydning for at undgå opspænding af glaspladen



ADVARSEL

Øyeskader og kuttskader på grunn av glasskår

- ▶ Bruk vernebriller
- ▶ Bruk kuttsikre hansker
- ▶ Beskytt glasskanter og -flater mot skader
- ▶ Sikre at glassplaten ikke kan falle
- ▶ Bearbeid kun uskadde komponenter
- ▶ Monter monteringsrammen uten mekanisk forskyvning for å unngå spenninger i glassplaten



VARNING

Risk för ögonskador och skärsår på grund av glassplinter

- ▶ Använd skyddsglasögon
- ▶ Använd skärtåliga skyddshandskar
- ▶ Skydda glaskanter och -ytor mot skador
- ▶ Säkra glasplattan mot vältnig
- ▶ Använd endast intakta komponenter
- ▶ Montera monteringsrammen utan mekanisk distorsion för att förhindra förspänningar i glasplattan



VAROITUS

Lasinsirujen aiheuttamat silmävammat ja viiltohaavat

- ▶ Käytä suojalaseja
- ▶ Käytä viiltosuojäkäsineitä
- ▶ Suojaa lasireunat ja -pinnat vaurioitumiselta
- ▶ Varmista lasilevy kaatumisen varalta
- ▶ Käsittele vain ehjiä osia
- ▶ Estä lasilevyyn kohdistuvat jännitykset asentamalla asennuskehys ilman mekaanista vetoa



AÐVÖRUN

Hætta á augnskaða og skurðum vegna glerbrota

- ▶ Notið hlífðargleraugu
- ▶ Notið skurðarþolna hlífðarhanska
- ▶ Hlífið glerbrúnum og glerflötum við skemmdum
- ▶ Komið í veg fyrir að glerplatan detti
- ▶ Notið eingöngu óskemmda íhluti
- ▶ Setjið festirammann upp án véllænnar truflunar til að koma í veg fyrir spennu í glerplötunni



OSTRZEŻENIE

Obrażenia oczu i obrażenia związane przecięciem odłamkami szkła

- ▶ Zakładać okulary ochronne
- ▶ Nosić rękawice odporne na przecięcie
- ▶ Chronić krawędzie i powierzchnie szklane przed uszkodzeniem
- ▶ Zabezpieczyć płytę szklaną przed upadkiem
- ▶ Poddawać obróbce wyłącznie nieuszkodzone komponenty
- ▶ Montować ramkę montażową bez mechanicznych zniekształceń, aby zapobiec odkształceniom płyty szklanej



FIGYELMEZTETÉS

Üvegszilánk okozta szemsérülés és vágott seb veszélye

- ▶ Viseljén védőszemüveget
- ▶ Viseljén vágásbiztos kesztyűt
- ▶ Óvja az üvegfelületet és az éleket a sérüléstől
- ▶ Biztosítsa az üveglapot eldőlés ellen
- ▶ Csak sértetlen komponenseket munkáljon meg
- ▶ A nyomólapprögzítő keretet mechanikai húzás nélkül szerelje, nehogy feszültség lépjen fel az üveglapban



VAROVANIE

Poranenie očí a rezné rany spôsobené úlomkami skla

- ▶ Používajte ochranné okuliare
- ▶ Používajte ochranné rukavice odolné proti porezaniu
- ▶ Sklenené hrany a plochy chráňte pred poškodením
- ▶ Sklenenú platňu zabezpečte proti pádu
- ▶ Na spracovanie používajte iba nepoškodené komponenty
- ▶ Upevňovací rám namontujte bez mechanickej deformácie tvaru, aby nedošlo k vytváraniu nadmerného vnútorného napätia sklenenej platne



VÝSTRAHA

Oční a řezná poranění skleněnými střepinami

- ▶ Noste ochranné brýle
- ▶ Noste rukavice odolné proti proříznutí
- ▶ Chraňte hrany a plochy skla před poškozením
- ▶ Zajistěte skleněnou desku proti skácení
- ▶ Zpracovávejte pouze nepoškozené komponenty
- ▶ Upevňovací rámeček namontujte bez mechanické deformace, abyste zamezili prnutí skleněné desky



OPOZORILO

Poškodbe oči in ureznine zaradi drobcov stekla

- ▶ Nosite zaščitna očala
- ▶ Nosite rokavice, odporne na ureznine
- ▶ Steklene površine in robove zaščitite pred poškodbami
- ▶ Steklenu ploščo zaščitite pred padcem
- ▶ Uporabite samo nepoškodovane dele
- ▶ Pritrdilni okvir namestite brez mehanskega napenjanja, da ne pride do napetosti v stekleni plošči



UPOZORENJE

Ozljede oka i porezotine krhotinama stakla

- ▶ Nosite zaštitne naočale
- ▶ Nosite rukavice otporne na porezotine
- ▶ Staklene rubove i površine zaštitite od oštećenja
- ▶ Staklenu ploču osigurajte od prevrtanja
- ▶ Obradujte samo neoštećene komponente
- ▶ Montažni okvir montirajte bez mehaničkog zatezanja kako bi se spriječilo naprezanje staklene ploče



UPOZORENJE

Povrede očiju i posekotine komadićima stakla

- ▶ Nositi zaštitne naočare
- ▶ Nositi rukavice otporne na rezove
- ▶ Staklene ivice i površine zaštititi od oštećenja
- ▶ Staklenu ploču obezbediti od prevrtanja
- ▶ Obradivati samo neoštećene komponente
- ▶ Montažni okvir montirati bez mehaničkog odlaganja da bi se sprečila zatezanja staklene ploče



HOIATUS

Klaasikildude tõttu silmavigastuste ja sisselõigete oht

- ▶ Kanda kaitseprille
- ▶ Kanda vastupidavaid kindaid
- ▶ Kaitsta klaasiservi ja -pindu kahjustuste eest
- ▶ Kaitsta klaasplaati ümberkukkumise eest
- ▶ Töötada ainult kahjustamata osadega
- ▶ Monteerida kinnitusraamid ilma mehaanilise viivitusega, et vältida klaasplaadis tekkivaid pingeid



BRĪDINĀJUMS

Acu savainojumi un stikla lausku izraisīti griezumi

- ▶ Nēsājiet aizsargbrilles
- ▶ Nēsājiet izturīgus cimdus
- ▶ Sargiet stikla malas un virsmas no bojājumiem
- ▶ Nodrošiniet stikla loksni pret nokrišanu
- ▶ Apstrādājiet tikai nebojātus komponentus
- ▶ Piemontējiet stiprinājuma rāmi bez mehāniskas stiepes, lai novērstu stikla loksnes nospriegojumu



ATSARGIAI

Akių sužeidimai ir stiklo duženų sukelti įpjovimai

- ▶ Nešiokite apsauginius akinius
- ▶ Mūvėkite nuo įpjovimų apsaugančias pirštines
- ▶ Užtikrinkite, kad stiklo kraštai ir paviršius nebūtų pažeisti
- ▶ Pasirūpinkite, kad stiklo plokštė nenukristų
- ▶ Naudokite tik nepažeistus komponentus
- ▶ Tvirtinimo rėmą montuokite taip, kad būtų išvengta mechaninės deformacijos ir kad stiklo plokštės neveiktų įtemptai



ПРЕДУПРЕЖДЕНИЕ

Нараняване на очите и порязване поради стъклені парченца

- ▶ Използвайте защитни очила
- ▶ Използвайте защитни ръкавици срещу порязване
- ▶ Пазете стъклените ръбове и повърхности от повреждане
- ▶ Подсигурете стъклената плоча против преобръщане
- ▶ Обработвайте само неповредени компоненти
- ▶ Монтирайте затегателните рамки без механично изкривяване, за да предотвратите деформация на стъклената плоча



AVERTIZARE

Rănire a ochilor și plăgi tăiate datorită cioburilor de sticlă

- ▶ Utilizați ochelari de protecție
- ▶ Purtați mănuși de protecție cu rezistență la tăiere
- ▶ Protejați muchiile și suprafețele din sticlă împotriva deteriorării
- ▶ Asigurați-vă ca placa de sticlă să nu cadă
- ▶ Prelucrați numai componente care nu prezintă deteriorări
- ▶ Montați rama de montare fără tensionare mecanică pentru a evita apariția unor tensionări la placa de sticlă



ΠΡΟΕΙΔΟΠΟΙΗΣΗ

Τραυματισμός οφθαλμών και τραυματισμός κοπής από θραύσματα γυαλιού

- ▶ Φοράτε προστατευτικά γυαλιά
- ▶ Φοράτε γάντια προστασίας από κοπή
- ▶ Προστατεύετε τις γυάλινες ακμές και επιφάνειες από ζημιές
- ▶ Ασφαλίζετε την υαλόπλακα από πτώση
- ▶ Επεξεργάζεστε μόνο άθικτα στοιχεία
- ▶ Τοποθετείτε το πλαίσιο στήριξης χωρίς μηχανικές παραμορφώσεις, ώστε να αποτρέπεται η άσκηση τάσεων στην υαλόπλακα



UYARI

Cam parçalanmalarından kaynaklanan göz ve kesik yaralanmaları

- ▶ Koruyucu gözlük kullanın
- ▶ Kesiğe karşı koruyucu eldiven kullanın
- ▶ Cam kenarlarını ve yüzeyini darbelere karşı koruyun
- ▶ Cam plakayı düşmeye karşı koruyun
- ▶ Sadece zarar görmemiş elemanları kullanın
- ▶ Cam plaka geriliminden korunmak için, montaj çerçevesini monte ederken mekanik bozulmadan kaçının



ОСТОРОЖНО

Повреждение глаз и порезы осколками стекла

- ▶ Использовать защитные очки
- ▶ Использовать прочные на разрез перчатки
- ▶ Защитить кромки и поверхности стекла от повреждений
- ▶ Зафиксировать стеклянную пластину от опрокидывания
- ▶ Работать только с неповрежденными компонентами
- ▶ Монтажную рамку устанавливать без механического перегиба для предотвращения деформации стеклянной пластинки



警告

玻璃碎片会伤害眼睛和引起割伤

- ▶ 戴上防护镜
- ▶ 穿戴耐切割的手套
- ▶ 防止玻璃边缘和表面受到损伤
- ▶ 采取措施防止玻璃板翻倒
- ▶ 仅处理未受损的部件
- ▶ 安装固定框架时不可产生机械变形，以避免玻璃板承受张力作用

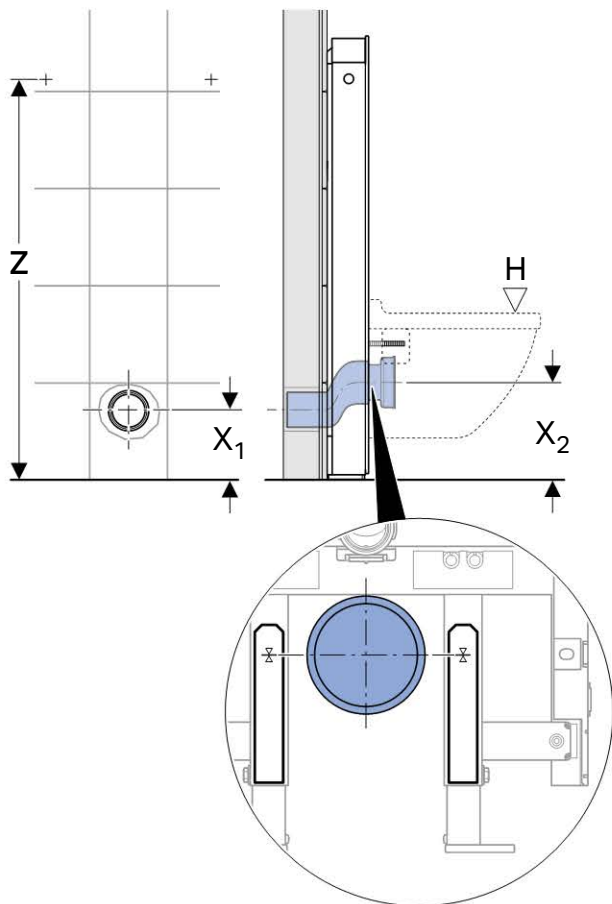
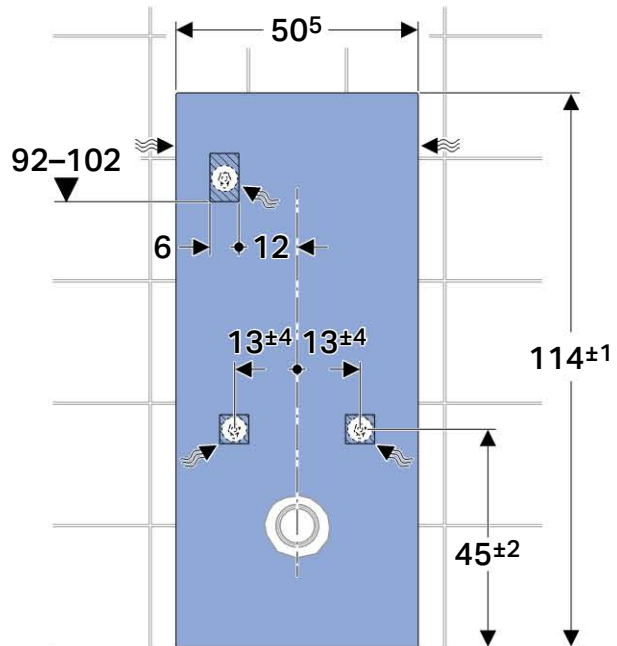
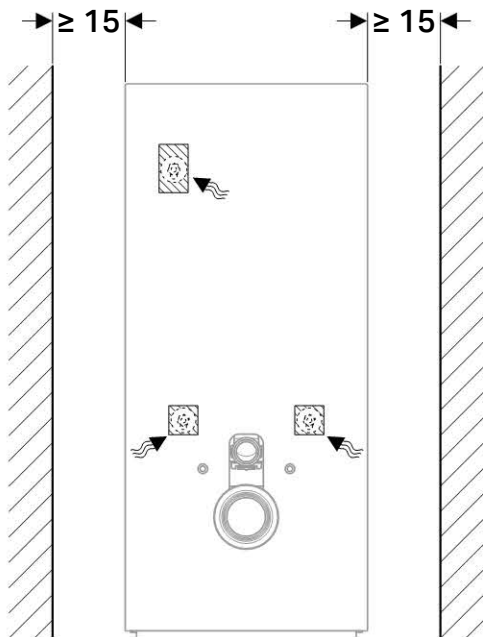
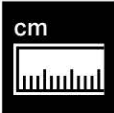

X ₁		X ₂	Z	H
24	0 cm	24	104	42 ^{±1}
25		25	104	43 ^{±1}
26		26	104	44 ^{±1}
21	3 cm 131.085.11.1	24	104	42 ^{±1}
22		25	104	43 ^{±1}
23		26	104	44 ^{±1}
24		27	106	45 ^{±1}
25		28	107	46 ^{±1}
26		29	108	47 ^{±1}
19	5 cm 388.352.29.1	24	104	42 ^{±1}
20		25	104	43 ^{±1}
21		26	104	44 ^{±1}
22		27	106	45 ^{±1}
23		28	107	46 ^{±1}
24		29	108	47 ^{±1}
25		30	109	48 ^{±1}
26		31	110	49 ^{±1}
17	7 cm 131.108.11.1	24	104	42 ^{±1}
18		25	104	43 ^{±1}
19		26	104	44 ^{±1}
20		27	106	45 ^{±1}
21		28	107	46 ^{±1}
22		29	108	47 ^{±1}
23		30	109	48 ^{±1}
24		31	110	49 ^{±1}
25		32	111	50 ^{±1}
26		33	112	51 ^{±1}



1

1

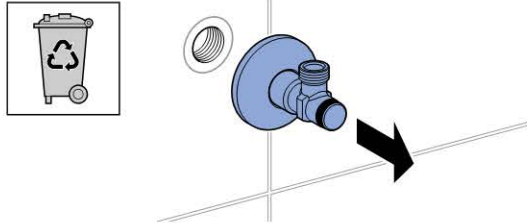

i

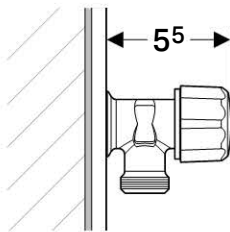

2

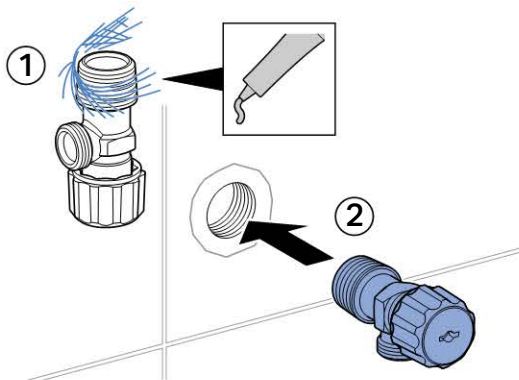

3

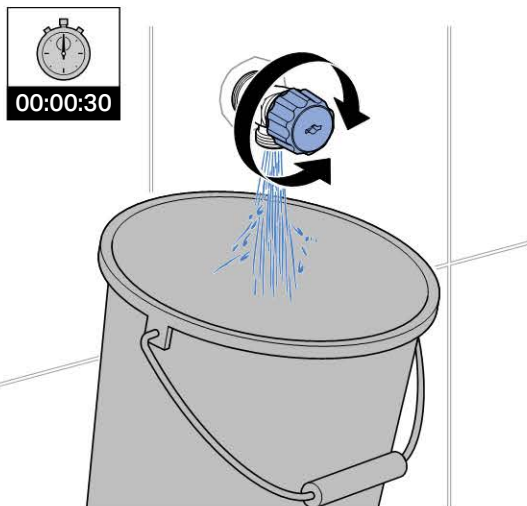

i

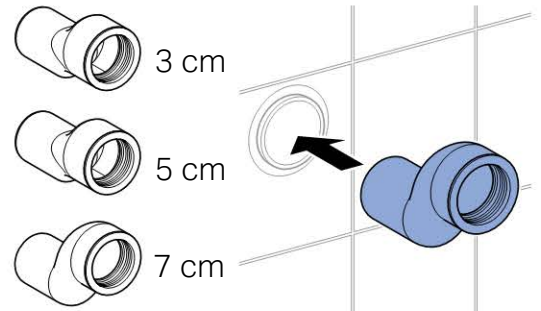
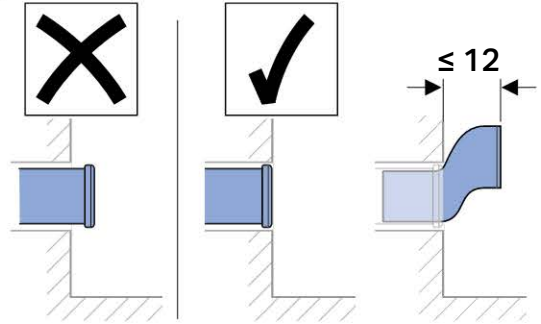

2

1

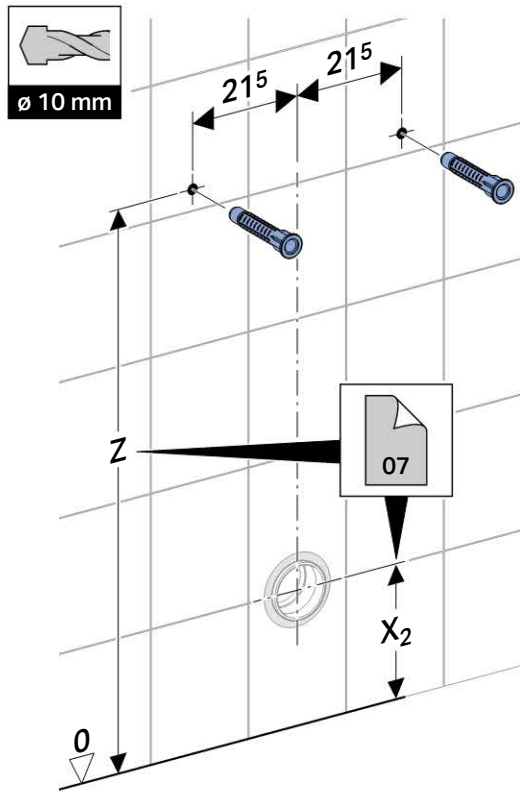

i

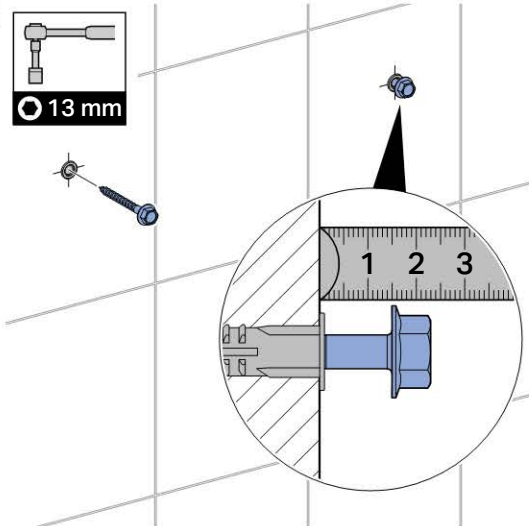

2

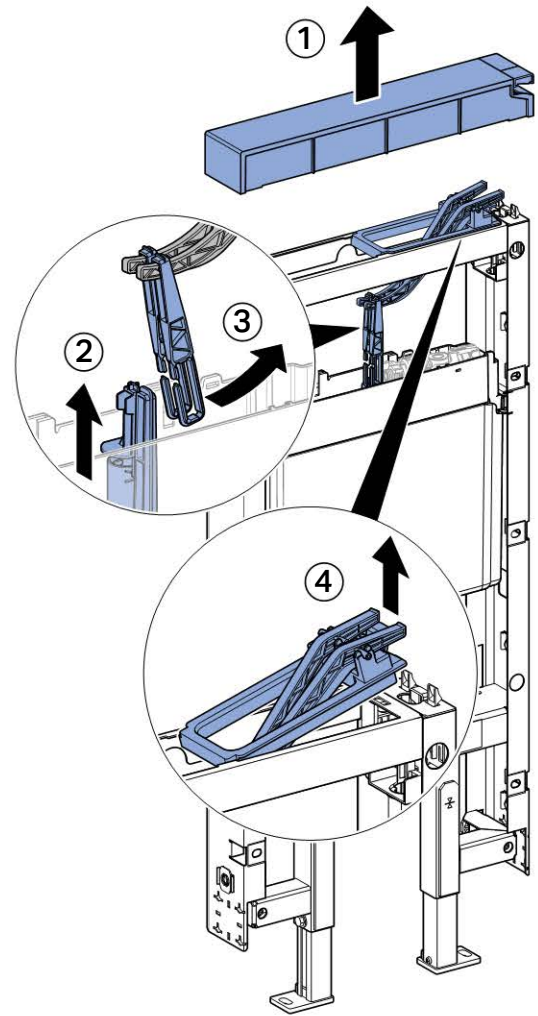

3

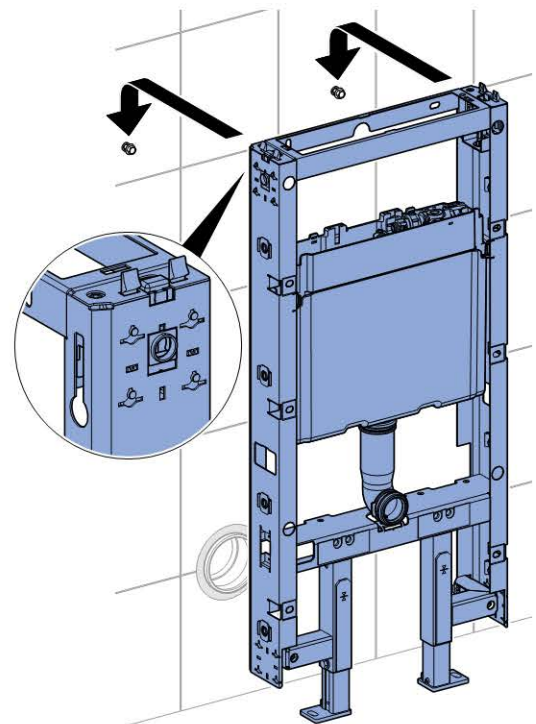

4

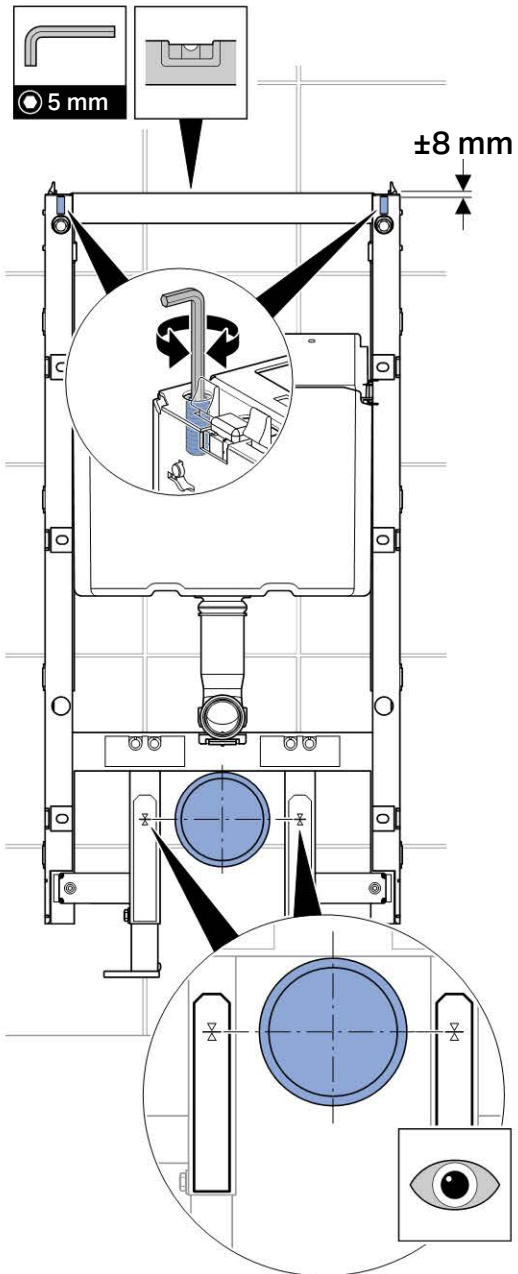

5

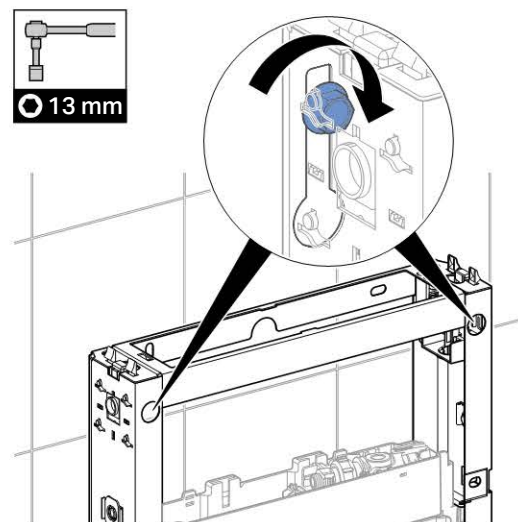

6

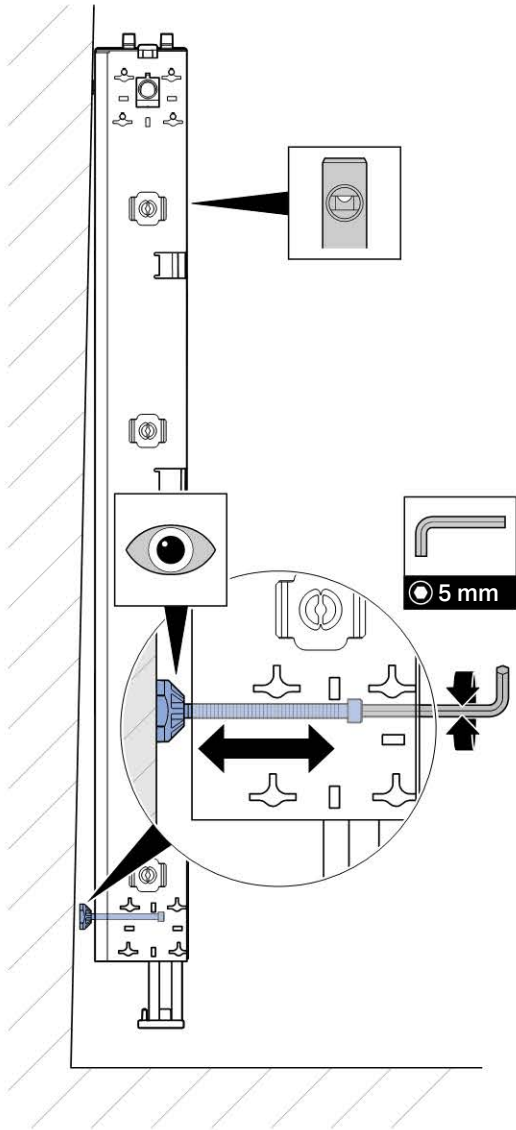

i

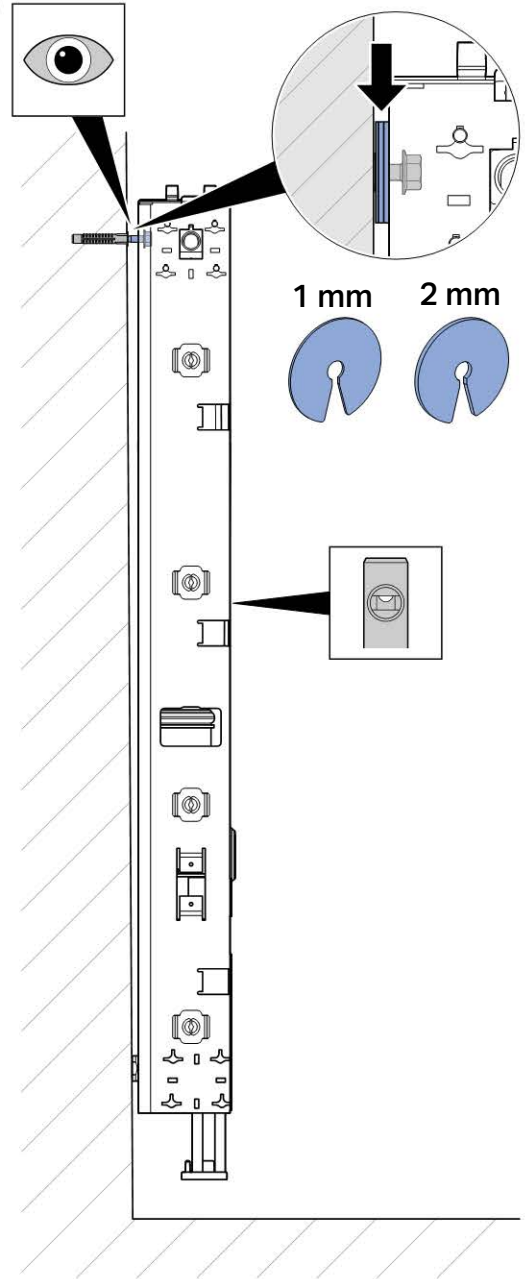

i

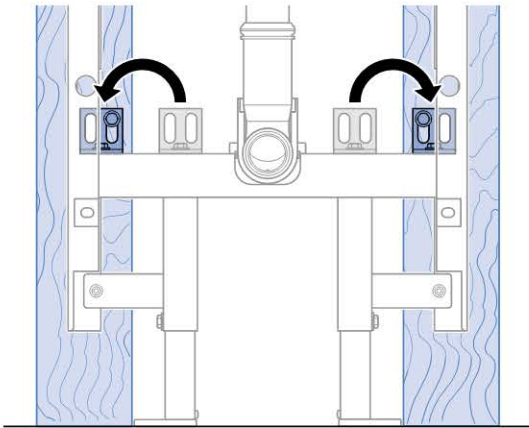

7

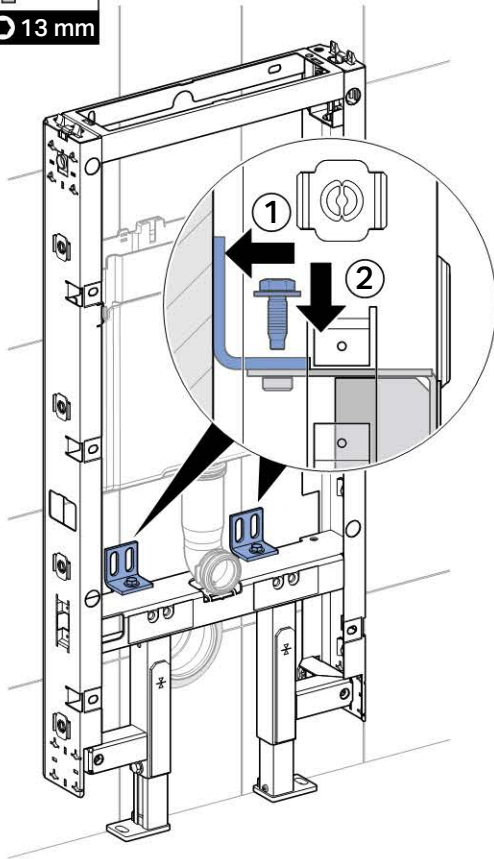
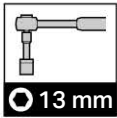

8

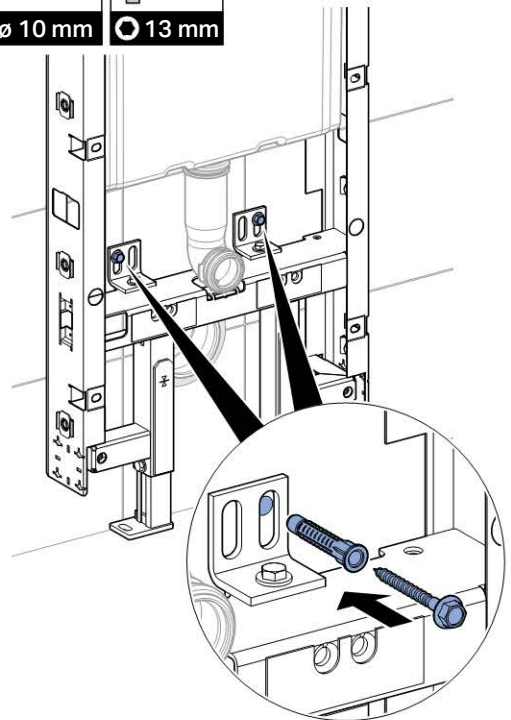
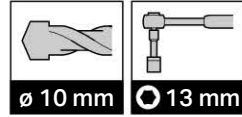

9

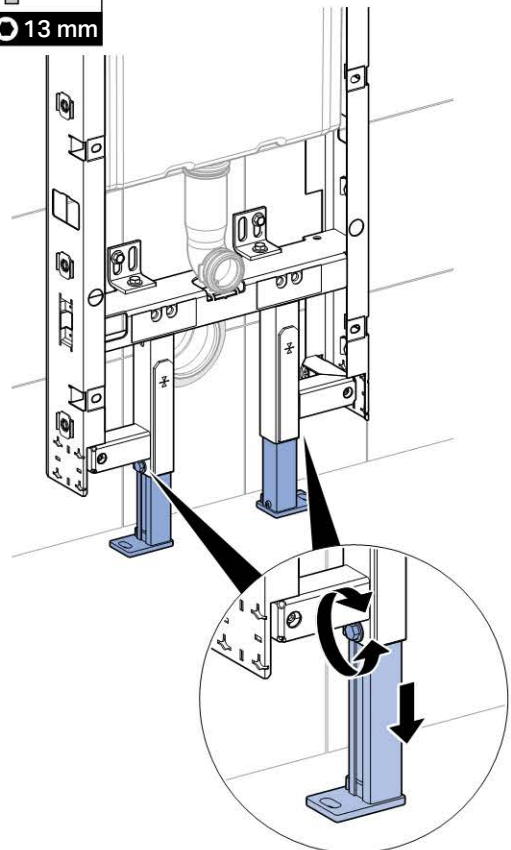
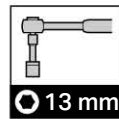

i

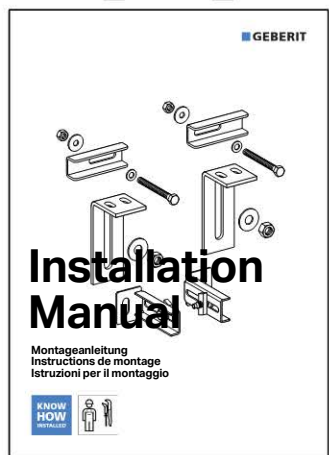
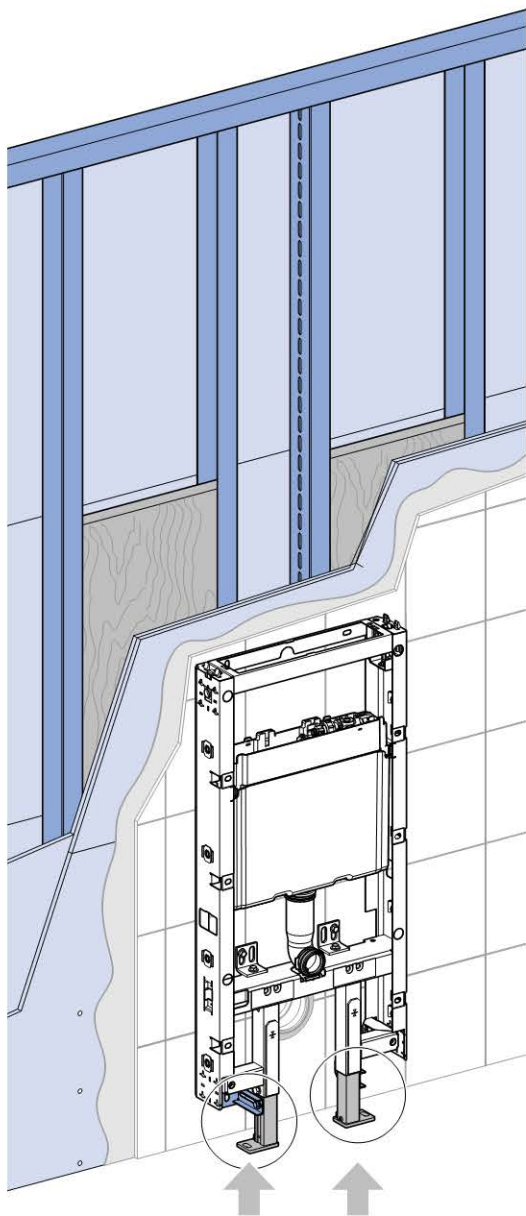

824.359.00.0

3

1

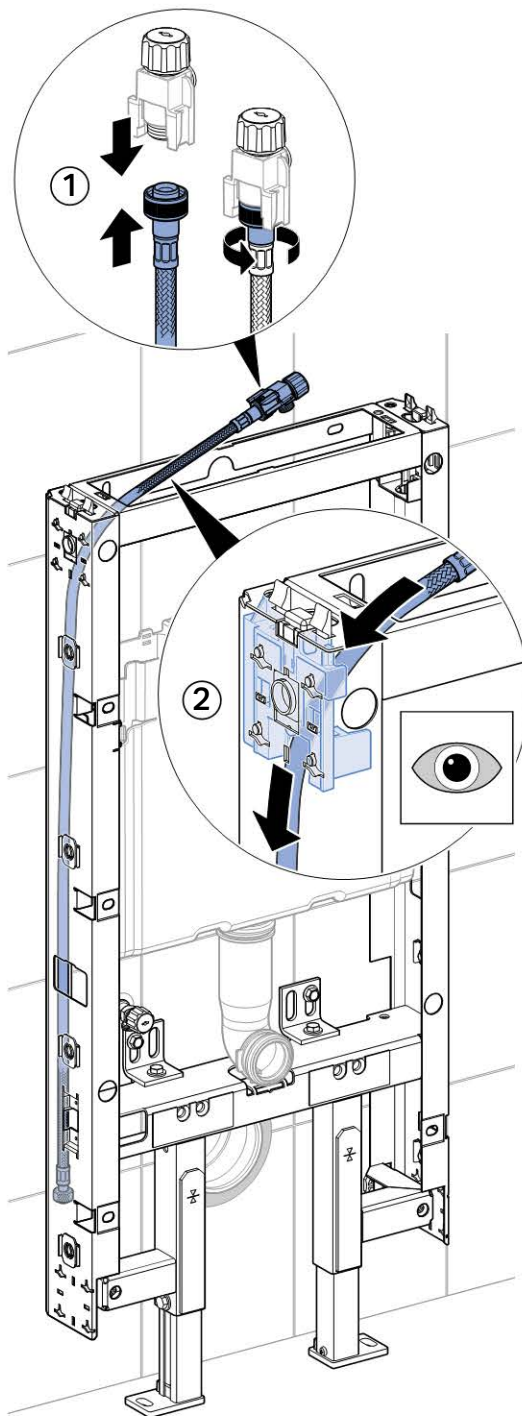

2

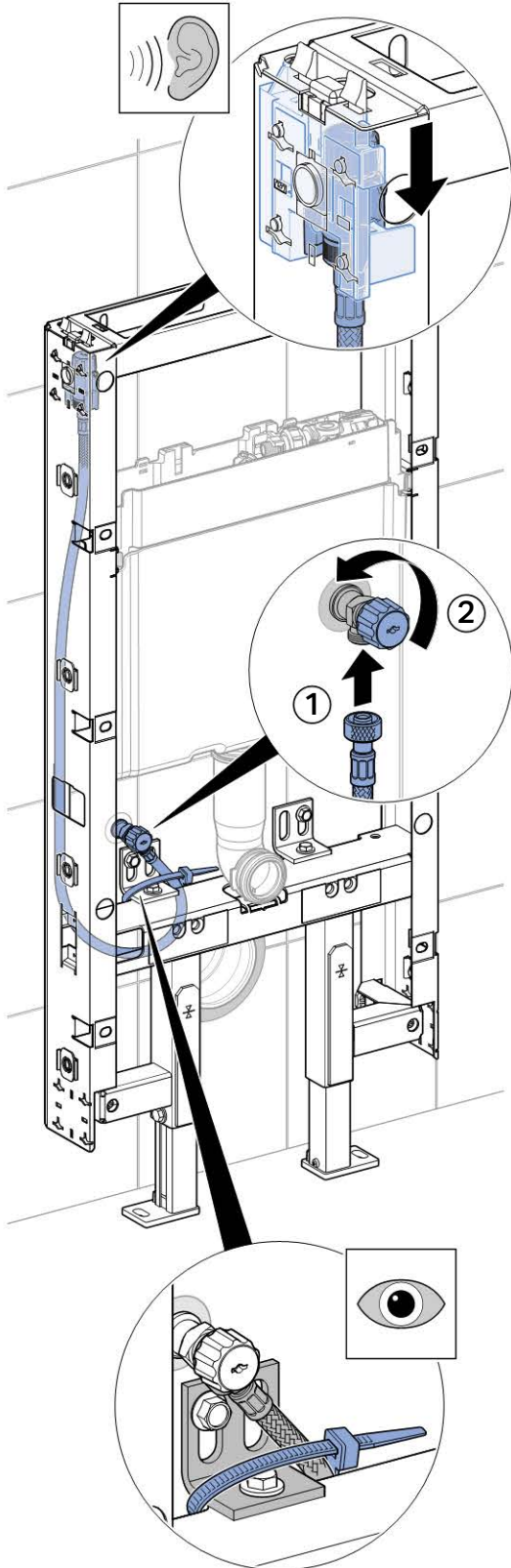

3

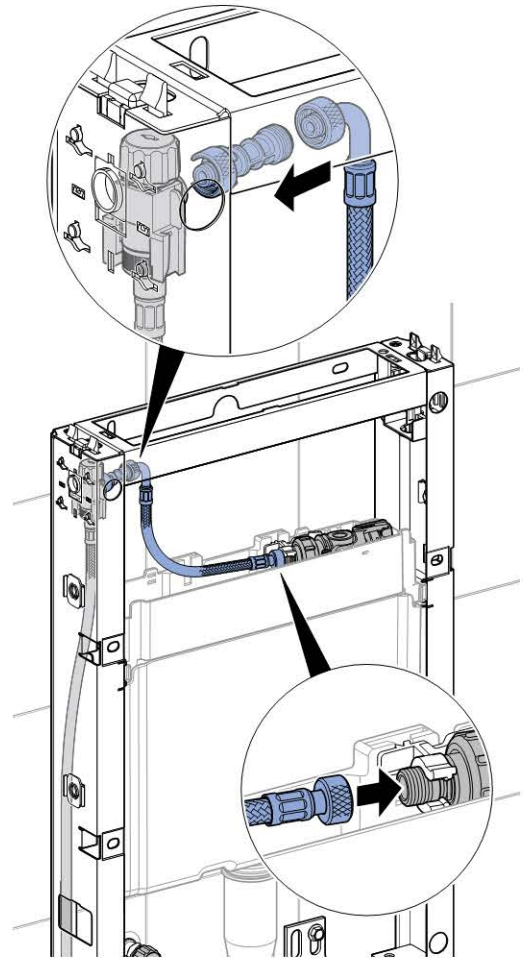

4

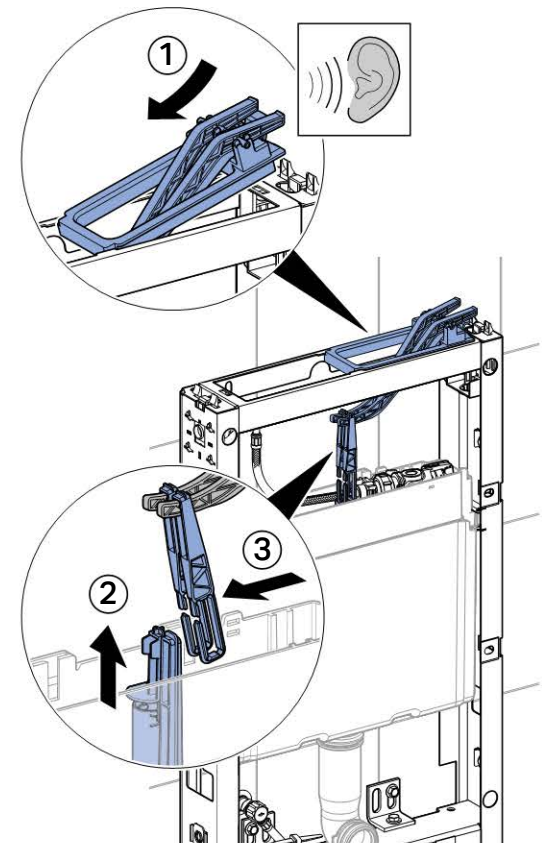

5

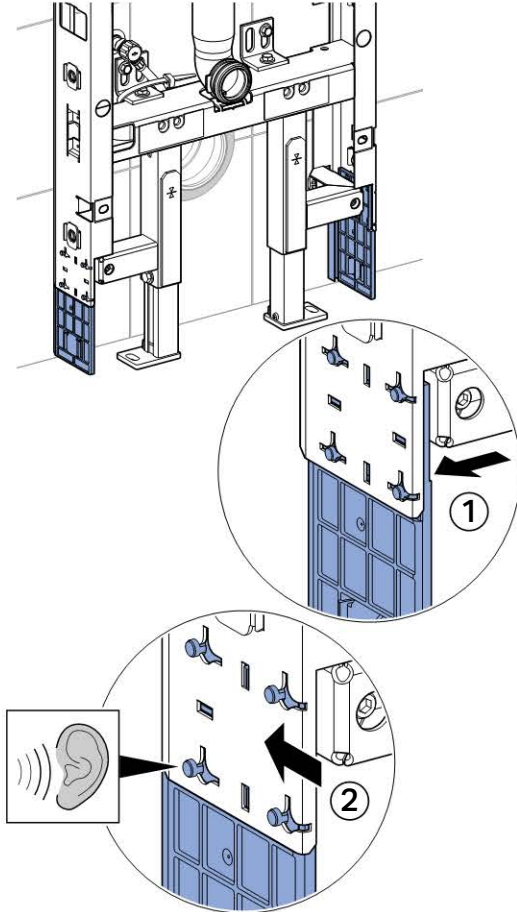

6

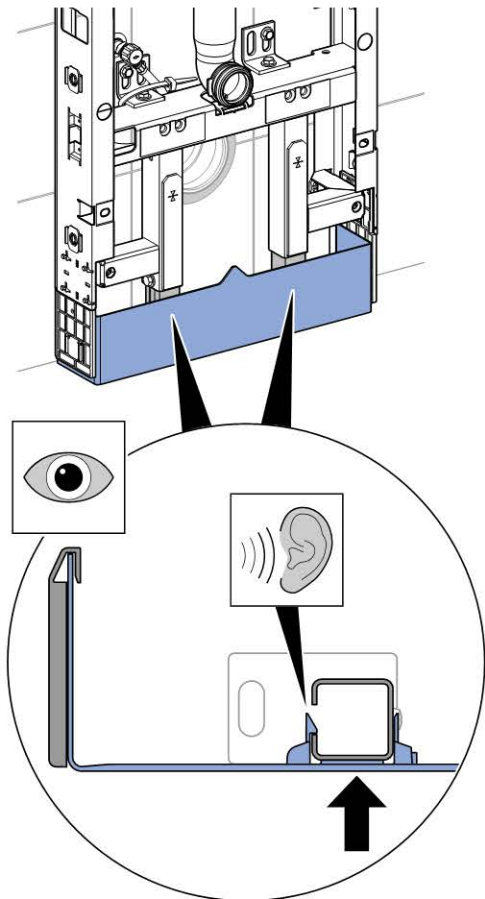

4



i

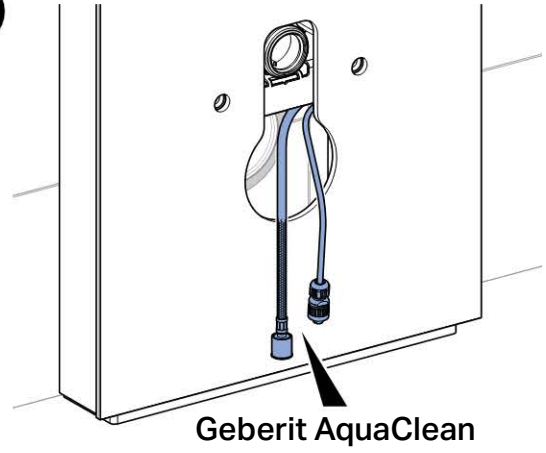

1

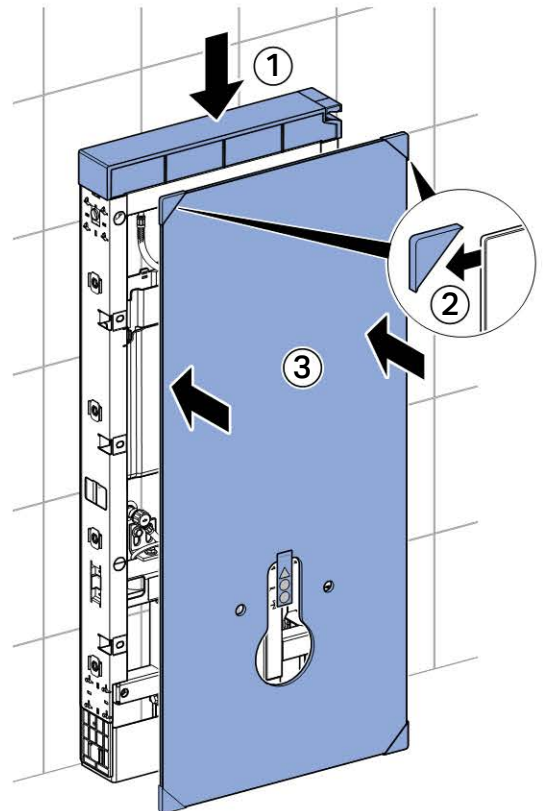

2

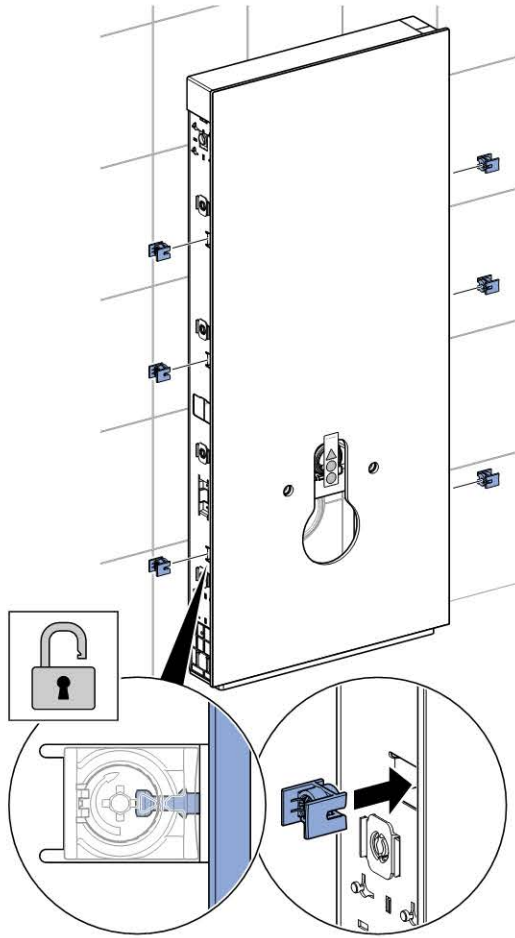

3

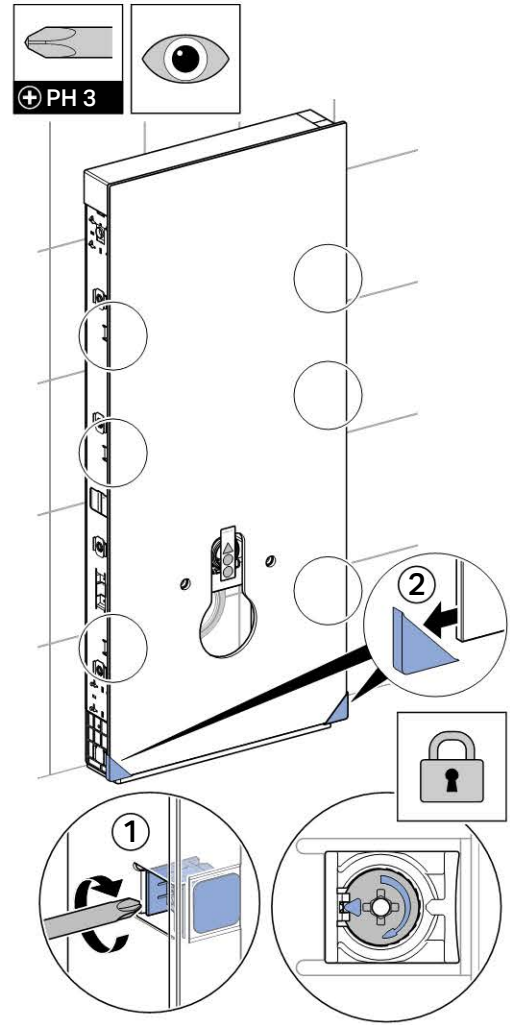

4

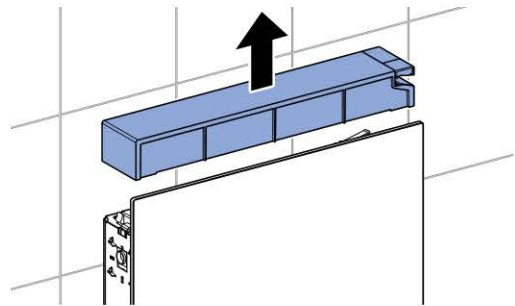

5

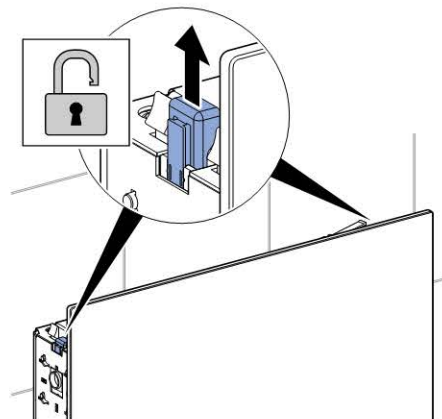

6

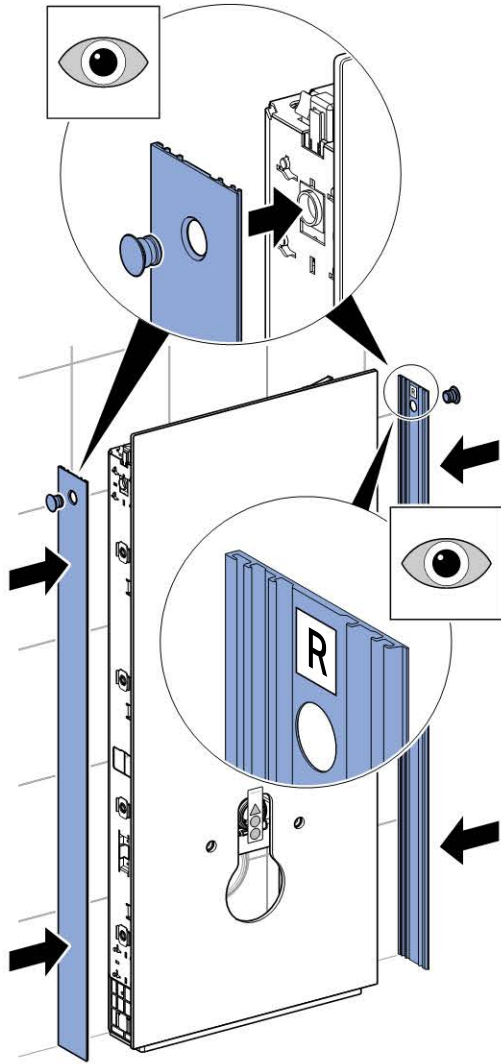

7

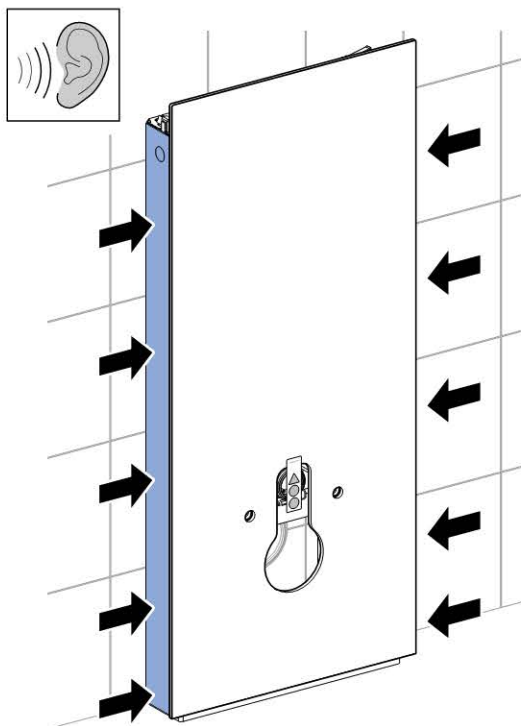

8

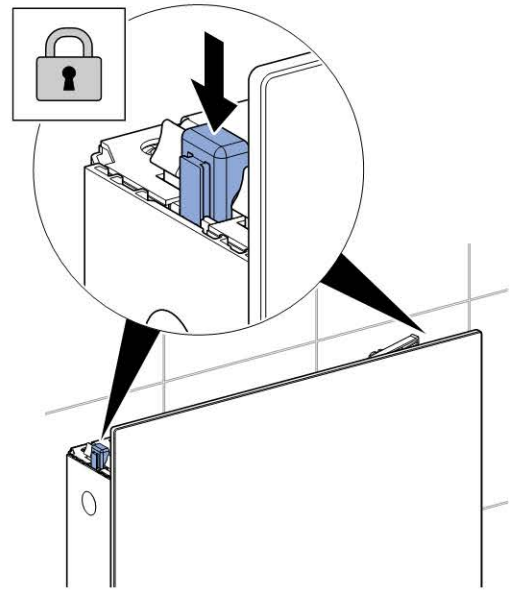

9

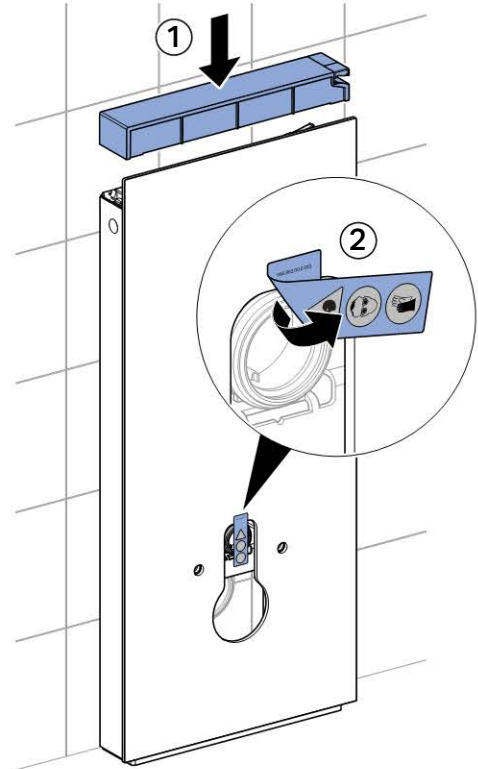

3

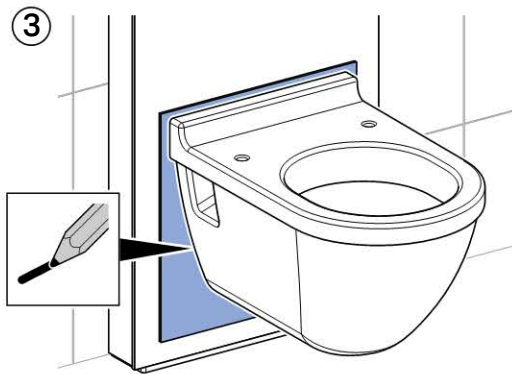
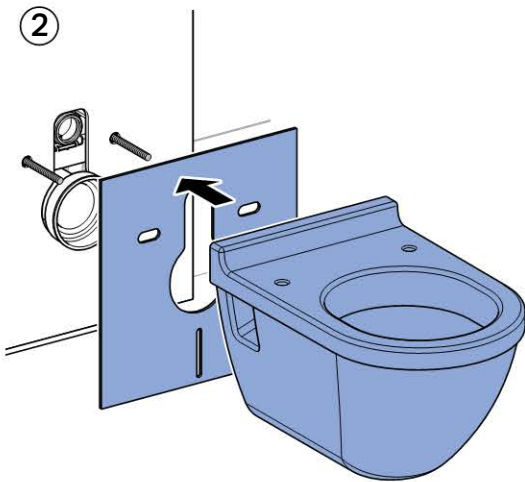
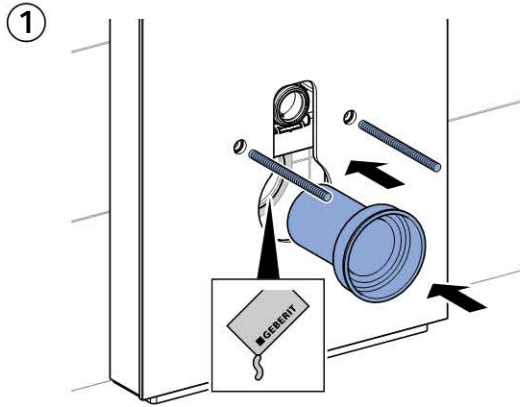

4

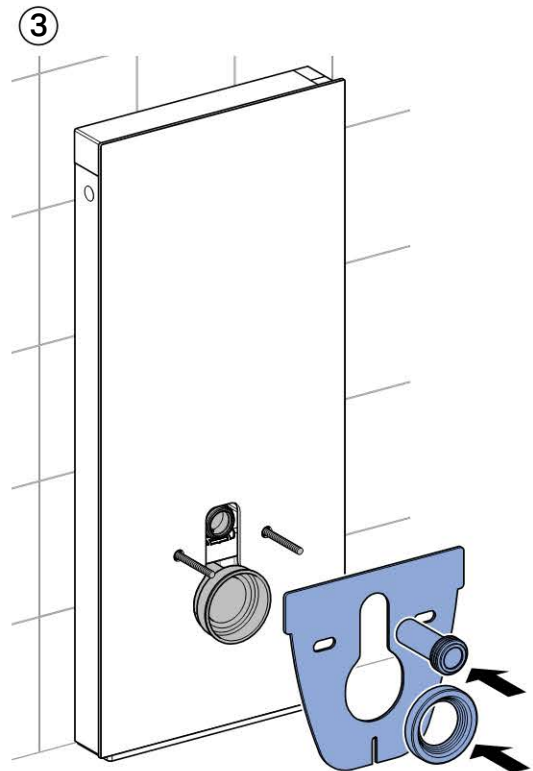
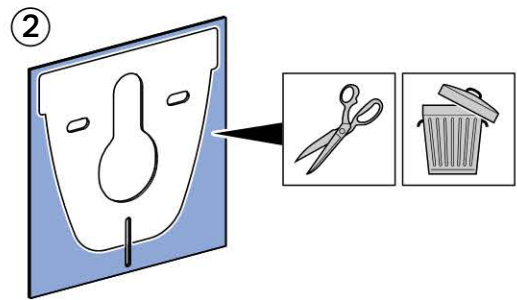
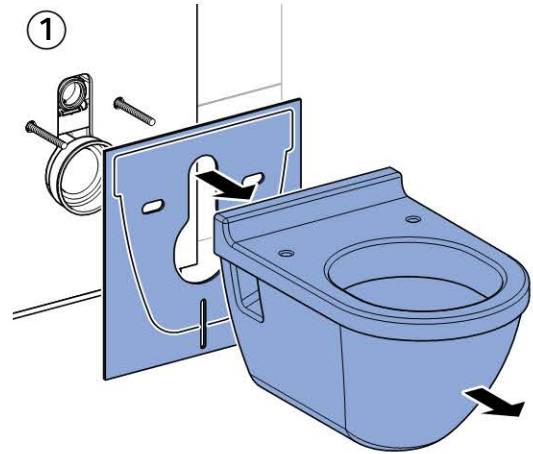

5



6

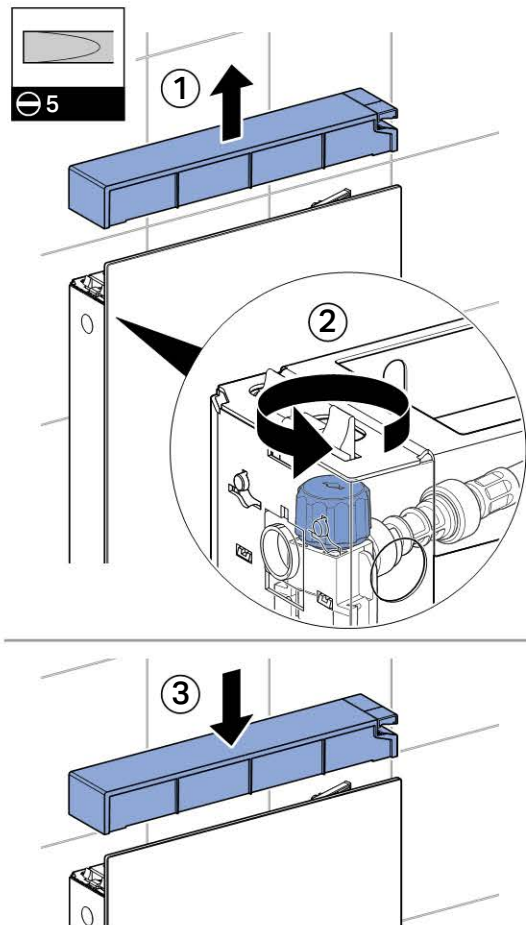

1



2

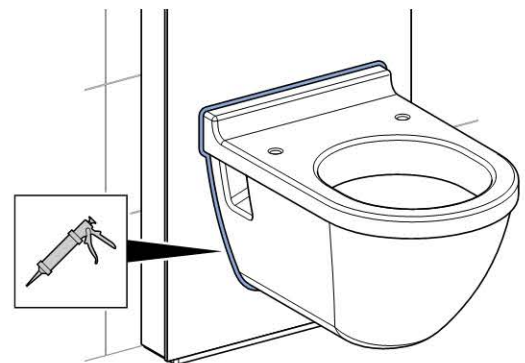

Geberit International AG, Schachenstrasse 77, CH-8645 Jona

T +41 55 221 63 00

F +41 55 221 63 16

documentation@geberit.com

→ www.geberit.com